

BYLAWS

of the

RACKING HORSE BREEDERS' ASSOCIATION OF AMERICA

(RHBAA)



RULES

Governing the showing, judging, officials,
care, shows, affiliates, classification,
identification and registration of
RACKING HORSES
Revised April 2008

**RACKING HORSE BREEDERS'
ASSOCIATION OF AMERICA**

67 Horse Center Road
Decatur, Alabama 35603
256/353-7225
FAX 256/353-7266

RACKING HORSE CELEBRATION

67 Horse Center Road
Decatur, Alabama 35603
256/353-7225
FAX 256/353-7266

Amended and Restated
ARTICLES OF INCORPORATION
and
BYLAWS
of
RACKING HORSE BREEDERS' ASSOCIATION
OF AMERICA, INC.
(A Nonprofit Corporation)

Dedicated
"For The Love Of The Breed"

TABLE OF CONTENTS FOR BYLAWS

ARTICLE I	1
OFFICES	1
1.1 Location.....	1
ARTICLE II	1
MEMBERSHIP AND MEETINGS OF MEMBERS	1
2.1 Members Qualification	1
2.2 Dues.....	2
2.3 Termination Of Membership	2
2.4 Annual Meeting	2
2.5 Special Meetings.....	2
2.6 List Of Members Entitled To Vote.....	2
2.7 Notice Of Meetings.....	3
2.8 Adjourned Meetings And Notice Thereof.....	3
2.9 Quorum	3
2.10 Voting	3
ARTICLE III	4
BOARD OF DIRECTORS	4
3.1 General Powers	4
3.2 Number Of Directors	4
3.3 Qualifications Of Directors	4
3.4 Election	4
3.5 Election Procedures.....	5
3.6 Term	7
3.7 Resignation And Removal.....	8
3.8 Vacancies.....	8
3.9 Quorum And Voting.....	8
3.10 Rules And Regulations: Record Of Meetings.....	9
3.11 Annual Meeting.....	9
3.12 Regular Meetings	10
3.13 Special Meetings.....	10
3.14 Notice Of Meetings: Waiver Of Notice.....	10
3.15 Committees Of Directors.....	11
3.16 Powers And Duties Of Committees.....	11

3.17 Executive Committee	11
3.18 Compensation Of Directors	12
3.19 Job Description Of Executive Director	12
3.20 Budget.....	15
3.21 Financial Statements.....	16
3.22 Action Without Meeting	16
ARTICLE IV.....	16
OFFICERS	16
4.1 Principal Officers	16
4.2 Election Of Principal Officers: Term of Office	16
4.3 Subordinate Officers, Agents And Employees	17
4.4 Delegation Of Duties Of Officers.....	18
4.5 Removal Of Officers.....	18
4.6 Resignations	18
4.7 President.....	18
4.8 Senior Vice President And Vice Presidents.....	18
4.9 Secretary.....	19
4.10 Treasurer.....	20
ARTICLE V.....	20
DESCRIPTION OF THE RACKING HORSE.....	20
5.1 General	20
5.2 Conformation.....	21
ARTICLE VI.....	21
BREEDERS' DIVISION	21
6.1 General Breeders' Committee.....	21
6.2 Registration By Qualification	22
6.3 Commissioners Qualifications.....	22
6.4 Age Of Horses As Shown By Teeth.....	23
6.5 Head Markings	29
6.6 Leg Markings.....	30
6.7 Nomenclature.....	31
6.8 Registration By Birth	31
6.9 Lead Line Ponies Registration	31
6.10 Registration Applications.....	31
6.11 Stallion Breeding Reports.....	32
6.12 Registration Fees	33
6.13 False Or Mistaken Pedigree.....	34
6.14 Certification	34

ARTICLE VII.....	34
<i>FUTURITY BREEDERS' NATIONAL FUTURITY.....</i>	34
7.1 General Provisions.....	35
7.2 Nomination Of Sire.....	35
7.3 Nomination Of Dam.....	35
7.4 Eligibility Of Weanlings.....	36
7.5 Eligibility Of Yearlings.....	36
7.6 Eligibility Of Two-Year-Olds.....	37
7.7 Eligibility Of Three-Year-Olds.....	37
7.8 Eligibility Of Three And Under Country Pleasure.....	37
7.9 Fees, Instatement, And Reinstatement Of Eligibility.....	38
7.10 Liability Of The Rhbaa.....	38
7.11 Money Equally Divided Among Fillies, Colts And Geldings.....	38
ARTICLE VIII.....	39
<i>SHOW DIVISION.....</i>	39
8.1 General.....	39
8.2 Show Committee.....	40
8.3 Age.....	40
8.4 Registration Required.....	40
8.5 Tack And Attire.....	41
8.6 Height Measurement.....	42
8.7 Shoeing Definitions.....	42
8.8 Gaits.....	45
8.9 Entering Ring.....	46
8.10 Workouts.....	46
8.11 Changing Of Tack.....	46
8.12 Time Outs.....	46
8.13 State Organizations.....	47
8.14 State Championship Shows.....	47
8.15 Regional Shows.....	49
8.16 All Breed Shows.....	49
8.17 Racking Horse World Celebration Election Of Judges.....	49
8.18 Show Affiliation/Sanctioning.....	50
ARTICLE IX.....	51
<i>JUDGING DIVISION.....</i>	51
9.1 Judges' Committee.....	51
9.2 Application And Apprenticeship.....	51

9.3 Judges Classification Systems.....	54
9.4 Requirements For Judging.....	55
9.5 Annual Relicensing Of Judges	56
9.6 License Denial, Revocation, Suspension.....	58
9.7 Code Of Professional Ethics For Licensed Judges.....	58
9.8 Judge's Pledge.....	59

ARTICLE X..... 60

EXHIBITORS STATUS..... 60

10.1 Exhibitor Status Committee.....	60
10.2 Definition Of Status	60
10.3 Exhibitor Show Cards.....	61
10.4 Amateur Show Card	62
10.5 Professional Show Card.....	63
10.6 Juvenile Show Card	64
10.7 Age Of Exhibitor	65
10.8 Change Of Status.....	65

ARTICLE XI..... 65

RACKING DIVISIONS..... 65

11.1 Trail, Field And Pleasure Division	66
11.2 Pleasure Division.....	66
11.3 Bitting In Pleasure Division.....	67
11.4 Trail Pleasure Division	67
11.5 Country Pleasure Division	68
11.6 Western Pleasure	69
11.7 Pleasure Racking	70
11.8 Park Pleasure Division	71
11.9 Show Pleasure Division.....	72
11.10 Style Pleasure Division.....	73
11.11 Model Halter	73
11.12 Lead Line Division	73
11.13 Flat Shod Division.....	74
11.14 Open Show Division	74
11.15 Specialty Action Division.....	75
11.16 Racking Horse To Bike	76
11.17 Racking Horse To Fine Harness.....	77
11.18 Spotted Racking Horses.....	78
11b.1 Pleasure Racking Horse Versatility Program.....	79
11b.2 Bitting In Pleasure Divisions	79

11b.3 Pleasure Divisions Classes	79
11b.4 Eligibility.....	79
11b.5 Class Descriptions.....	80
11b.6: Racking Horse Breeders' Association Of America National Pleasure Versatility Awards.....	96
11b.7 General Requirements	98
11b.8 Basic Obstacle Courses	98
11c.1 "Rack Across America" Trail Hours Program.....	99
ARTICLE XII.....	101
<i>CLASS SPECIFICATION, JUDGING PERCENTAGE, SANCTIONED CLASSES AND RETIREMENT CEREMONIES...</i>	<i>101</i>
12.1 Class Specification And Judging Percentages.....	101
12.2 Racking Seat Equitation/Equitation Classes	103
12.3 Championship/Stake Classes	108
12.4 Fall World Championship	108
12.5 Halter Classes.....	109
12.6 Conformation Judging	110
12.7 Yearling And Weanling Shoeing	111
12.8 Guidelines For Judging Futurity Halter Classes.....	111
12.9 Sanctioned Classes	112
12.10 Unauthorized Entering Of Center Ring	115
12.11 Retirement Ceremonies.....	115
ARTICLE XIII.....	115
<i>SHOW OFFICIALS AND RESPONSIBILITIES</i>	<i>115</i>
13.1 General	115
13.2 Suggestions To Promote A Successful Horse Show	121
ARTICLE XIV	123
<i>ADVISORY BOARD.....</i>	<i>123</i>
14.1 General	123
ARTICLE XV	123
<i>PERSONNEL AND PROPERTY COMMITTEE.....</i>	<i>123</i>
15.1 General	123

ARTICLE XVI	124
DQP COMMITTEE	124
16.1 Composition	124
16.2 Purpose	124
ARTICLE XVII	125
NATIONAL RULES ENFORCEMENT COMMITTEE	125
17.1 General	125
17.2 Persons Bound By Rules	125
17.3 Preliminary Enforcement, Procedure	126
17.4 Hearing Before Rules Enforcement Committee	127
17.5 Procedure For Appeal To The RHBAA Board Of Directors To Review Class D And E Violations	128
ARTICLE XVIII	130
RULES VIOLATIONS, PENALTIES and PROCEDURE	130
Part A - Violations	130
18.1 Exhibitor, Owner, Trainer, Breeder And Member Violations	130
18.2 Violations By Judges	133
Part B-Penalties	135
18.3 Penalties Classification	135
ARTICLE XIX	136
INDEMNIFICATION	136
19.1 Indemnification	136
ARTICLE XX	136
AMENDMENTS OF BYLAWS	136
20.1 By Members	136
20. 2 By Board Of Directors	136
ARTICLE XXI	137
MISCELLANEOUS	137
21.1 Corporate Seal	137
21.2 Fiscal Year	137
21.3 Notice: Waiver Of Notice	137
21.4 Execution Of Instruments, Contracts, Etc	138

BYLAWS OF RACKING HORSE BREEDERS' ASSOCIATION OF AMERICA, INC

ARTICLE I OFFICES

Section 1.1 LOCATION: The address of the registered office of the Racking Horse Breeders' Association of America, Inc. (hereinafter referred to as RHBAA or the Association) shall be the address of the principal office at the Celebration show ground in Priceville, Alabama, which address currently is 67 Horse Center Road, Decatur, Alabama. The registered agent shall be that person specified pursuant to Section 10-3A-24 of the Alabama Nonprofit Corporation Act.

ARTICLE II MEMBERSHIP AND MEETINGS OF MEMBERS

Section 2.1 MEMBERS QUALIFICATION: A potential member in the RHBAA must be initially endorsed by an existing Member of the RHBAA who is in good standing and he must pay the required annual dues. In order to vote on any matter within the RHBAA, the Member must be 18 years old or older, must have paid the annual dues of the association for the current year, or be a lifetime member, must not be delinquent on any debt to the RHBAA (defined as three months past due as of the date of the election), must not be on probation or suspension for a Class D or E violation, and must have been a member at least by December 31 of the previous year.

The Rules Enforcement Committee shall be responsible for determining the eligibility of a Member to vote under this rule. No juvenile may vote, nor shall Juvenile Members be counted for the purpose of determining a quorum.

Section 2.2 DUES: The annual dues shall be set by the Board of Directors and may only be changed in the preceding year.

Section 2.3 TERMINATION OF MEMBERSHIP: Membership in the RHBA shall terminate upon the occurrence of any of the following events:

- (a) The receipt by the Board of Directors of the written resignation of a Member, duly executed by such Member or the attorney-in-fact thereof.
- (b) The death of a Member.
- (c) The failure of a Member to pay dues, fines, or assessments on or before the due date thereof.
- (d) The determination by a majority of the Board of Directors that a Member has acted in such a manner as to demonstrate a willful disregard for the rules and purposes of this Association and repetitive refusal to abide by them.

Section 2.4 ANNUAL MEETING: The annual meeting of the Members of the RHBA shall be held in the first two months of each year at such time and place as may be fixed by the Board of Directors, but it must be held within the State of Alabama.

Section 2.5 SPECIAL MEETINGS: Special meetings of Members may be called at any time by the President, by a majority of the full Board of Directors, or by notice signed by at least 20% of the Members of the Association who are entitled to vote. Special meetings of the Members must be held within the State of Alabama.

Section 2.6 LIST OF MEMBERS ENTITLED TO VOTE: The Members entitled to vote at the annual or special meeting of Members shall be any Member qualified under Section 2.1. The Members entitled to vote for election of Directors shall be those

Members qualified under Section 2.1 and not determined to be disqualified by the Rules Enforcement Committee.

Section 2.7 NOTICE OF MEETINGS: Written notice of each annual or special meeting of Members, stating the time and place of the meeting, shall be mailed by US mail at least 10 days prior to the meeting to the address of each Member as shown on file with the RHBAA and notice of the purpose of such meeting must be given for all special meetings. Mailing of such notice shall not be required for the annual meeting provided at least 30 days prior to any such annual or special meeting, the required notice has been published in any newspaper or other publication having a general circulation to the Members, notwithstanding the fact that all Members may not subscribe thereto.

Section 2.8 ADJOURNED MEETINGS AND NOTICE THEREOF: Any meeting of Members may be adjourned to another time or place and the Association may transact at any adjourned meeting any business that might have been transacted at the original meeting. Notice need not be given of the adjourned meeting if the time and place thereof are announced at the meeting at which the adjournment is taken, unless any adjournment or series of adjournments caused the original meeting to be adjourned for more than thirty days after the date originally fixed therefore.

Section 2.9 QUORUM: At any meeting of the Members, 5% of the Members entitled to vote or act at such meeting shall be present in order to constitute a quorum for the transaction of any business, but less than a quorum shall have power to adjourn any meeting until a quorum shall be present. When a quorum is once present to organize a meeting, the quorum cannot be destroyed by the subsequent withdrawal of any Member.

Section 2.10 VOTING: At any meeting of Members, each Member present and entitled to vote shall cast one vote on each matter submitted to a vote at such meeting.

ARTICLE III

BOARD OF DIRECTORS

Section 3.1 GENERAL POWERS: The property, business and affairs of the RHBAA shall be managed by or under the direction of the Board of Directors. The Board of Directors may exercise all such powers of the Association and have such authority to do all such lawful acts and things as are permitted by law, the Articles of Incorporation or these Bylaws.

Section 3.2 NUMBER OF DIRECTORS: The Board of Directors of RHBAA shall consist of not less than three persons. The exact number of Directors which shall constitute the whole Board of Directors shall be established by July 15 of each year for the next ensuing election of Directors by Members of the Association, and shall be calculated based upon the number of Members entitled to vote in each of the States as set forth in Section 3.4 below as of such date. The Immediate Past President shall be an ex-officio member of the Board for a 12-month period following his term of office. He shall not be entitled to vote if he is no longer an elected director.

Section 3.3 QUALIFICATIONS OF DIRECTORS: To qualify to be elected as a Director, a person must be a Member entitled to vote, must be in good standing, must have been a Member for at least three full consecutive calendar years prior to the year of the election, must not have been convicted of a felony, must be of high moral character, must be at least 21 years of age as of January 1 of the year in which his term begins, and must be a resident of the State or Voting Region from which such Director is to be elected.

Section 3.4 ELECTION:

- (a) Except as otherwise provided by law, the Articles of Incorporation or these Bylaws, Directors of the Association shall be elected on a State-by-State basis, with Members entitled to vote for and elect only such Directors as the size of membership in their State permits. Members resident in any particular state shall not be entitled to elect a Director

unless the total membership in the State entitled to vote equals or exceeds 40. Members of any particular state shall be entitled to elect one additional Director when the members entitled to vote reaches 125 in number, and thereafter shall be entitled to elect an additional Director for every 100 members entitled to vote over 125.

- (b) Members in States with a membership of less than 40 will be grouped together in Voting Regions and shall be entitled to elect Directors based upon such aggregated membership size as set forth in Section 3.4 (a) above. The grouping into Voting Regions shall be established by the Association's Board of Directors in an effort to ensure that each voting Region shall be represented in proportion to the number of Members of the Association residing therein, and the decision of the Board of Directors as to such groupings shall be at its sole discretion, final and not subject to appeal. The decision of the Board of Directors as to the grouping of Members into Voting Regions shall be made at the same time that the determination of the number of Directors of the Association for the upcoming year is made.
- (c) Directors shall be elected no later than the thirty-first day of December of each year. Their terms shall commence at the beginning of the first Board of Directors meeting to be held the succeeding year as set forth herein. Elections of Directors shall be conducted by mail as set forth in Section 3.5 hereof.
- (d) The Directors elected shall be those receiving the highest number of votes cast without regard to whether a majority of the votes cast were received.
- (e) A candidate for election to a directorship shall qualify for election by submitting an application to the RHBAA office on or before August 15 prior to the election, and paying a fee of \$25.00.

Section 3.5 ELECTION PROCEDURES: A 12 member Election Committee, and a Chairman thereof, will be appointed by the Executive Committee of the Board of Directors of the Association. No more than two Members from any particular State or Voting Region may serve on the Election Committee. No candidate for

election positions may be allowed to participate with regard to election in which he or she is a candidate with exception to voting as a RHBAAs member eligible to vote. The Election Committee will be responsible for supervising, preparing and distributing election ballot packets and will be solely responsible for tabulating election results in accordance with the following procedures.

- (a) The Election Committee will prepare and distribute to each Member a ballot packet, including a letter explaining the election procedures with voter instructions included, a list of the Members who qualified to run from such Member's State or Voting Region, a ballot card and a postage paid return envelope with such Member's membership number, and State or Voting Region, and a line for such Member's signature on the front of the envelope.
- (b) The return envelope will be addressed to a post office box reserved by the Election Committee solely for election returns. Ballots shall be required to be received in the Election Committee post office box by December 15. All returned ballots will be retrieved from the Election Committee post office box by December 31 by two designated Election Committee Members, and delivered unopened, directly to the Election Committee for tabulation. Any ballots discovered open at the Election Committee tabulation meeting will be considered ineligible.
- (c) All returned envelopes will be placed in separate stacks for each State or Region and arranged in numerical order by membership number, and Members' numbers will be crosschecked against the list of Members entitled to vote. If the Election Committee receives more than one ballot for the same Member's number, only one ballot shall be counted, such valid ballot to be determined based on the Member's signature.
- (d) All envelopes will be opened face down, ballots removed and envelopes placed aside. After all envelopes are opened and ballots removed, both envelopes and ballots will be counted as a final cross-check of the total number of votes cast. Election Committee Members will then tabulate election results. Other Members of the RHBAAs may observe tabulation so long as there is no interference or attempted participation in the process.

- (e) After all results have been tabulated, with results being noted by the Chairman of the Election Committee, and prior to adjournment of the Election Committee Meeting, both returned envelopes and ballots will be securely sealed in separate boxes, to be retained for safekeeping by the Election Committee Chairman. In case of a disputed election, boxes may be opened only upon the approval of the Executive Committee and opened in the presence of six or more Election Committee Members.
- (f) The written results of the election showing the number of votes for each candidate as noted by the Chairman of the Election Committee shall be held in the office of the RHBAA and such results shall be available to any member of the RHBAA who may request it.
- (g) In the case of a tie between two or more candidates, a runoff election shall be held between those candidates alone, pursuant to the procedures set forth above, in accordance with regulations established by the Board of Directors of the RHBAA in order to enable the run-off election to be completed prior to the Annual meeting of the Directors of the RHBAA.
- (h) Any substantial deviation from the procedures set forth above shall constitute a violation of the election process, and the election may be declared null and void by the Executive Committee of the RHBAA.

Section 3.6 TERM:

- (a) Each director shall serve until his successor shall have been duly elected and qualified except in the event of the early termination of his term of office by reason of death, resignation, removal, or otherwise. No person shall be eligible to be a director for more than two full consecutive terms; however, a director may serve more than two non-consecutive terms. All terms previously served including terms currently being served that were effective 1-1-2005 shall be considered in calculating these term limits.
- (b) Directors shall serve for terms of three years. (2/19/05)

Section 3.7 RESIGNATION AND REMOVAL: Any Director may resign at any time upon written notice to the Board of Directors, the President, or the Secretary. The resignation of any Director shall take effect upon receipt of notice thereof or at such later time as shall be specified in such notice, and unless otherwise specified therein, the acceptance of such resignation shall not be necessary to make it effective. Any Director who fails to attend two consecutive meetings of the Board of Directors may be removed by majority vote of the Board of Directors. However, if a Director shall miss three consecutive meetings he shall be automatically removed from office, unless expressly excused by the full Board of Directors for hardship reasons. A Director who misses more than 50% of the meetings of the Board of Directors, excused, or unexcused, during the first two-thirds of his term shall not be eligible for re-election to the Board of Directors.

Section 3.8 VACANCIES: Vacancies in the Board of Directors shall be filled by a majority vote of the Board of Directors. Each Director chosen to fill a vacancy on the Board of Directors shall hold office until the end of the term of the Director whose departure caused the vacancy and until his successor shall be elected and qualified.

- (a) There must be an election held for a resigned/vacated seat of the Board of Directors, if the expired term is greater than nine months.

Section 3.9 QUORUM AND VOTING:

- (a) At all meetings of the Board of Directors, a majority of the total number of Directors shall be required to be present in person to constitute a quorum for the transaction of business. A Director interested in a contract or transaction may be counted in determining the presence of a quorum at a meeting of the Board of Directors which authorized the contract or transaction. In the absence of a quorum, a majority of the Directors present may adjourn the meeting until a quorum shall be present.
- (b) If authorized by a majority of the Directors present in person, members of the Board of Directors, or any committee

designated by the Board of Directors, may participate in a meeting of the Board of Directors or such committee by means of a conference telephone or similar communications equipment by means of which all persons participating in the meeting can hear each other, and participation in such a meeting shall constitute presence in person at such meeting.

- (c) The vote of the majority of the Directors present at a meeting at which a quorum is present shall be the act of the Board of Directors; moreover, when a quorum is once present to organize a meeting, a quorum cannot be destroyed by the subsequent withdrawal of a Director.

Section 3.10 RULES AND REGULATIONS: RECORD OF MEETINGS:

- (a) The Board of Directors shall have the authority to make, amend, repeal and enforce such rules and regulations as it may deem necessary or advisable with respect to the conduct, management and activities of the RHBAA, the admission, classification, qualification, suspension, expulsion or discipline of Members (including the right to levy fines), the basis for removal of Director or Officers, the conduct of meetings of Members or of the Board of Directors and any other applicable or appropriate subjects relating to the purposes of the Association.
- (b) The Board of Directors may hold its meetings at such places and times as it may wish, but the books and records of the Association shall be kept and maintained at its principal office as set above in Section 1.1.
- (c) All motions that are voted on shall be by a "Roll Call" vote recorded by the Secretary of the Board or Executive Committee. (9/23/04)

Section 3.11 ANNUAL MEETING: An annual meeting of the Board of Directors shall be called and held at least 10 days prior to the annual membership meeting of each year for the purpose of organization, election of Officers, consideration of the budget and transaction of any other business.

- (a) An annual meeting of the general membership shall be

called and held at the Fall Celebration and the Winter Meetings.

Section 3.12 REGULAR MEETINGS: Regular meetings of the Board of Directors shall be held at the time and place as shall from time to time be determined by the Board of Directors. After there has been such determination and notice thereof has been given to each member of the Board of Directors, no further notice shall be required for any such regular meeting. Except as otherwise provided by law, any business may be transacted at any regular meeting.

Section 3.13 SPECIAL MEETINGS: Special meetings of the Board of Directors may, unless otherwise prescribed by law, be called from time to time by the President, and shall be called by the President or the Secretary upon the written request of a majority of the whole Board of Directors directed to the President or the Secretary. Except as provided below, notice of any special meeting of the Board of Directors, stating the time, place and purpose of such special meeting, shall be given to each Director be present at such meeting.

Section 3.14 NOTICE OF MEETINGS: WAIVER OF NOTICE: Notice of any meeting of the Board of Directors shall be deemed to be duly given to a Director (i) if mailed to such Director addressed to him at his address as it appears upon the books of the Association, or at the address last made known in writing to the RHBAA by such Director at least five days before the day on which such meeting is to be held, or (ii) if sent to him at such address by facsimile or telegraph, not later than three days before the day on which such meeting is to be held. Each such notice shall state the time and place of the meeting. Notice of any meeting of the Board of Directors need not be given to any Director if waived by him in writing (or by facsimile or telegram whether before or after the holding of such meeting), or if such Director is present at such meeting. Any meeting of the Board of Directors shall be a duly constituted meeting without any notice thereof having been given if all Directors then in office shall be present at such meeting.

Section 3.15 COMMITTEES OF DIRECTORS: The Board of Directors may designate one or more permanent standing committees, each committee to consist of two or more of the Directors of the Association. Except as hereinafter provided, vacancies in membership of any permanent committee shall be filled by the vote of a majority of the whole Board of Directors. Members of a permanent committee shall hold office for such period as may be fixed by a resolution adopted by a majority of the whole Board of Directors, subject, however, to removal at any time by the vote of a majority of the whole Board of Directors. The President of the RHBAA may appoint special, temporary committees to perform specific tasks; the completion of which shall terminate the Committee, provided the Board of Directors may overrule the President's appointment of any special committee.

Section 3.16 POWERS AND DUTIES OF COMMITTEES: Any committee appointed by the Board of Directors shall have only such power and authority as is expressly given to it by the Board of Directors and these Bylaws. Each committee may adopt its own rules of procedure and may meet at stated times or on such notice as such committee may determine. Every permanent, standing committee shall keep regular written minutes of its proceedings and file such minutes with the RHBAA office within thirty days of each meeting and shall present said minutes at the next full board meeting. Failure to comply with this requirement shall constitute cause for the termination of the Chairman of the committee at the discretion of the Board of Directors.

Section 3.17 EXECUTIVE COMMITTEE: There is hereby created an Executive Committee consisting of the President, a Senior Vice President and Vice Presidents in charge of the following permanent, standing committees, to-wit: DQP Committee, Rules Enforcement Committee; Breeders' Committee, Judges Committee; Horse Show Committee; Exhibitor Status Committee; Trail, Field and Pleasure Committee, Personnel and Property Committee, Promotions and Membership Committee and Advisory Committee. At the discretion of the Board of Directors, the Executive Committee may also include up to three additional Directors who shall be designated to serve as Vice Presidents and/or Chairmen of any

additional committees, which the Board of Directors determines should be represented on the Executive Committee. If not otherwise a member of the Executive Committee, the Immediate Past President, the Secretary and the Treasurer shall be ex officio members of the Executive Committee, entitled to attend meetings of the Executive Committee but with no power to vote, unless such person is an elected Director currently serving on the Board. Each member of the Executive committee shall serve for a term of one year or until his successor is duly elected and qualified. Executive Committee members may serve consecutive terms. Meetings of the Executive committee shall be called by the President or by the Secretary upon written requests from a majority of the Committee, in either case upon ten days' written notice given by Secretary of the Executive Committee. Notice may be waived by a Member as to himself. At all meetings of the Executive Committee, a majority thereof shall constitute a quorum. All power of the Board of Directors is hereby vested in the Executive Committee, but all actions of the Executive Committee are subject to review and ratification by the full Board of Directors. Executive Committee members shall immediately cease to serve as Executive Committee members when they cease to hold the titles or offices entitling them to be on the Executive Committee.

Section 3.18 COMPENSATION OF DIRECTORS: Each Director shall be entitled to receive, for attendance at each meeting of the Board of Directors or any duly constituted committee thereof which he attends, such fee, if any, as is fixed by the Board, and in connection with such attendance may be reimbursed by the Association for travel expenses. The fees to such Directors may be fixed in unequal amounts among them, taking into account their respective relationships to the RHBAA in other capacities. These provisions shall not be construed to preclude any Director from receiving compensation in serving the RHBAA in any other capacity.

Section 3.19 JOB DESCRIPTION OF EXECUTIVE DIRECTOR: The Board of Directors may employ an Executive Director on such terms as the Board of Directors elects. The job description and duties of the Executive Director shall be set out

hereinafter. General: The Executive Director shall be a salaried employee of the RHBAA and he may not be a director of the RHBAA, nor may he have any profit-making business dealings of any kind, directly or indirectly, with the RHBAA except for his employment and the normal participation as a member in the services and activities offered by the RHBAA to its members. The employment of the Executive Director may only be terminated by the full Board of Directors.

The Executive Director shall be the general manager of the business and affairs of the RHBAA, and as such, he shall be in charge of the RHBAA office, all personnel, the day-to-day financial affairs of the RHBAA, the show grounds and all property of the RHBAA, including its care and maintenance, and he shall assist and cooperate with all officers and committee chairmen in the performance of their respective functions. The Executive Director shall coordinate with the President and/or Treasurer, in their respective capacities, and shall be absolved from accountability and responsibility in undertaking anything authorized in writing by either the President or Treasurer; however, no expenditure of funds disapproved by the Treasurer may be made until the Board of Directors approves the same. The President and Treasurer shall be accountable to the Board of Directors for any action taken or authorized by them on behalf of the RHBAA and may, at the discretion of the Board of Directors, be held personally liable for any such action taken or authorized by either of them without the prior approval of the Board of Directors.

SPECIFIC AUTHORITY AND RESPONSIBILITY

- (a) Office Manager: One of the prime responsibilities of the Executive Director shall be managing the office and business affairs of the RHBAA. The Executive Director shall be responsible for managing all of the office personnel, maintaining complete and accurate files of all the business of the RHBAA, managing and maintaining complete and accurate financial records, and conducting the normal everyday business affairs of the RHBAA.
- (b) Event Funding: An important function of the Executive Director will be to seek and obtain the rental and use of the RHBAA facilities by horse shows and other groups in order to make the RHBAA a profitable operation. The Executive

Director shall be expected to actively seek the use by other organizations of the RHBAA facilities. In this connection, the Executive Director shall be expected to be responsible for fund raising, by way of seeking advertisements and/or sponsorships, for the Spring and Fall Celebration horse shows. The profitability of the RHBAA shall be the prime concern of the Executive Director, and he shall be expected to account to the Board of Directors from time to time as to the financial status of the operation of the RHBAA.

- (c) Personnel: The Executive Director shall be in charge of all personnel of the RHBAA and the Executive Director may hire and/or fire any employee of the RHBAA in his discretion, but any new permanent personnel position must be approved by the Board of Directors or the Executive Committee. The Executive director may also suspend any permanent or temporary employee without pay until the next meeting of the Board of Directors or Executive Committee. The pay of all permanent personnel shall be set by the Board of Directors upon the recommendation of the Executive Director.
- (d) Finances: The Executive Director shall have the authority to make ordinary, reasonable and necessary expenditures in the operation of the day-to-day affairs of the RHBAA; and he may make extraordinary expenditures authorized in writing by the President and/or Treasurer as set out above. The Executive Director shall be responsible for keeping the books of the RHBAA, and he shall be responsible for balancing the accounts of the RHBAA at the end of each month.
- (e) Property: The Executive Director shall be responsible for maintaining all of the property of the RHBAA, and keeping said property in good condition, as well as maintaining reasonable and necessary insurance on said property, subject to the approval or disapproval of the Board of Directors.
- (f) Standing Committees: The Executive Director is expected to cooperate with each standing committee and officer of the Board of Directors in performing the respective functions of each. The Executive Director is expected to

understand that each standing committee functions and performs its job independently of the Executive Director, President, Treasurer, or other officer, such committees being responsible only to the Board of Directors. The Executive Director is also expected to understand that each such committee will require the assistance of the Executive Director and of the office staff in performing the function of such committee, and the Executive Director is expected to give this assistance. However, because the Executive Director is responsible for the financial operation of the RHBAA, and its ultimate profitability or not, no expenditure of the funds of the RHBAA can be made or authorized without the express approval or authorization of the Executive Director, President or Treasurer as set out above. In dealing with the office staff of the RHBAA, it is expected that all committee heads and officers of the RHBAA will work through the Executive Director, because the Executive Director is in charge of the office.

- (g) Public Relations: It is expected that the Executive Director, as the general manager and representative of the RHBAA, will be active in public affairs and in the promotion of the RHBAA. The Executive Director shall be expected to attend and promote horse shows and events of the RHBAA as his work schedule will permit. Although the promotion of the RHBAA is an important job of the Executive Director, he shall make no extraordinary expenditures in the promotion of the RHBAA without the prior approval of the Board of Directors.

Section 3.20 BUDGET: The Treasurer shall prepare a detailed proposed budget for the Association for each year and shall submit such proposed budget to the Board of Directors for its consideration at its annual meeting. After the Board of Directors has approved the budget as proposed or modified, expenditures under the approved budget may not be exceeded in total amount by more than 5% without prior approval by a majority of the members of the Executive Committee or the Board of Directors.

Section 3.21 FINANCIAL STATEMENTS: A financial statement of the Association at and as of the end of each fiscal year shall be prepared in accordance with generally accepted accounting principles by an independent certified public accountant within 90 days of such fiscal year end. The Board of Directors may, but is not required to, direct that such financial statement be audited. The financial statements shall be delivered to the Board of Directors at its next regular or special meeting following their completion.

Section 3.22 ACTION WITHOUT MEETING: Unless otherwise restricted by the Articles of Incorporation, any action required or permitted to be taken at any meeting of the Board of Directors or of any committee thereof may be taken without a meeting if a written consent thereto is signed by all members of the Board of Directors or of such committee, as the case may be, and such written consent is filed with the minutes of the proceedings of the Board of Directors or such committee.

ARTICLE IV OFFICERS

Section 4.1 PRINCIPAL OFFICERS: The principal officers of the Association shall be elected by the Board of Directors and shall include a President, a Senior Vice President, Vice Presidents as identified herein of certain committees and Divisions of the RHBA, a Secretary and a Treasurer and may, at the discretion of the Board of Directors, also include additional Vice Presidents and a Controller. Except as otherwise provided in the Articles of Incorporation or these Bylaws, one person may hold the offices and perform the duties of any two or more of said principal offices, except the office and duties of President and Secretary. The principal officers must also be Members of the Association, and all principal officers, except the Secretary and the Treasurer, must also be members of the Board of Directors.

Section 4.2 ELECTION OF PRINCIPAL OFFICERS: TERM OF OFFICE: The principal officers of the RHBA shall be elected annually by the Board of Directors at the annual meeting of the

Board of Directors. Failure to elect any principal officers annually shall not dissolve the Association. If the Board of Directors shall fail to fill any principal office at any annual meeting, or if any vacancy in any principal office shall occur, or if any principal office shall be newly created, such principal office may be filled at any regular or special meeting of the Board of Directors. Each principal officer shall hold office for a term of one year or until his successor is duly elected and qualified. Prior to the end of each year, the Board of Directors shall appoint a Nominating Committee consisting of five of its members, of which no more than two shall be residents of any one particular state or voting region. The Nominating Committee shall, not less than 21 days in advance of the Annual Meeting of Directors, submit to the RHBA A report nominating Members to each of the Association's principal office and to any additional positions on the Executive Committee as determined by the Board pursuant to Section 3.17 of these Bylaws. The report of the Nominating Committee shall be submitted to the Board of Directors by mail, and elections for officers and additional Executive Committee members shall be held at the annual meeting of the Board of Directors. Nominations for each officer's position or for any additional Director positions on the Executive Committee may also be offered from the Board of Directors at large, and the election of such position shall not be undertaken until all nominations have been made. All officers and other members of the Executive Committee must receive a majority of the votes cast in order to be elected. The Board of Directors may promulgate such additional rules as it deems necessary or advisable to establish procedures for the election of officers.

Section 4.3 SUBORDINATE OFFICERS, AGENTS AND EMPLOYEES: In addition to the principal officers, the Association may have such Assistant Secretaries, Assistant Treasurers and other subordinate officers, agents and employees as the Board of Directors may deem advisable, each of whom shall hold office for such period and have such authority and perform such duties as the Board of Directors, the President, or any officer designated by the Board of Directors, may from time to time determine. The RHBA A Attorney of Record and/or Board of Directors Attorney shall be licensed in the State of Alabama and shall not be a member

of the RHBA. The Board of Directors at any time may appoint and remove, or may delegate to any principal officer the power to appoint and to remove any subordinate officer, agent or employee of the RHBA.

Section 4.4 DELEGATION OF DUTIES OF OFFICERS:

The Board of Directors may delegate the duties and powers of any officer of the Association to any other officer or to any Director for a specified period of time for any reason that the Board of Directors may deem sufficient.

Section 4.5 REMOVAL OF OFFICERS: Any officer of the Board may be removed, with cause, by resolution by a majority of the Directors then in office

Section 4.6 RESIGNATIONS: Any officer may resign at any time by giving written notice of resignation to the Board of Directors, to the President or to the Secretary. Any such resignation shall take effect upon receipt of such notice or at any later time specified therein. Unless otherwise specified in the notice, the acceptance of a resignation shall not be necessary to make the resignation effective.

Section 4.7 PRESIDENT: The President shall preside at all meetings of the Members, of the Board of Directors and of the Executive Committee at which he is present. The President shall have all powers and duties usually incident to the office of President, except as specifically limited by a resolution of the Board of Directors. The President shall have such other powers and perform such other duties as may be assigned to him from time to time by the Board of Directors. The President shall be an ex-officio member (and is not entitled to vote) of every committee, permanent or temporary, of the RHBA, and he shall act as liaison between each committee and the Board of Directors, as well as liaison between the Executive Director and staff and the Board of Directors.

Section 4.8 SENIOR VICE PRESIDENT AND VICE PRESIDENTS: In the absence or disability of the President, or if the office of the President be vacant, the Senior Vice President

shall perform the duties and exercise the powers of the President, subject to the right of the Board of Directors at any time to extend or confine such powers and duties or to assign them to others. The other Vice Presidents shall generally assist the President or the Board of Directors in such manner as the Board shall direct, and may chair committees or divisions as provided in these Bylaws. The Vice Presidents shall have such other powers and perform such other duties as may be assigned to them from time to time by the Board of Directors.

Section 4.9 SECRETARY: The Secretary of the RHBAAs shall be a full time salaried employee of the RHBAAs, may not be a Director of the RHBAAs and is to answer to the President. The following are duties that will be required by the person, plus the normal duties of a Corporate Secretary:

1. Sign all documents that require a signature of the Secretary.
2. Keep records of all the proceedings of the RHBAAs available to the Membership for viewing in the office at all times.
3. Maintain the RHBAAs web site to all required items as per by-laws and other news that pertains to the operations of the RHBAAs.
4. Have all minutes of Board, Membership and Executive Meetings recorded by a recording service, and post them 15 days after such meeting.
5. Keep an active Membership and Voting Membership list for all meetings.
6. Oversee all mailing required in by-laws to Membership.
7. Obtain the agenda for all meetings and post as per by-laws on web site.
8. To work with Executive Director on all office items, in the absence of Executive Director to be in charge of office and financial activities, with the Treasurer's advice pertaining to the RHBAAs.
9. To serve as Secretary of Executive Committee and other items that may occur.

The person employed as Secretary of the RHBAAs to be ratified by the Board of Directors and the employment of the Secretary can only be terminated by the full Board of Directors.

Section 4.10 TREASURER: The Treasurer shall have general supervision over the care and custody of the funds and over the receipts and disbursements of the Association, and shall cause the funds of the RHBAA to be deposited in the name of the Association in such banks or other depositories as the Board of Directors may designate. The Treasurer shall have supervision over the care and safekeeping of any securities of the Association. The Treasurer shall be the chief accounting officer of the RHBAA and shall have supervision over the maintenance and custody of the accounting operation of the Association, including the keeping of accurate accounts of all receipts and disbursements and all other financial transactions. The Treasurer shall be responsible for preparing a proposed annual budget for the Association and submitting it to the Board of Directors for consideration at its annual meeting. The Treasurer shall have all powers and duties usually incident to the office of Treasurer, except as specifically limited by a resolution of the Board of Directors. The Treasurer shall have such other powers and perform such other duties as may be assigned to him from time to time by the Board of Directors or the President.

ARTICLE V

DESCRIPTION OF THE RACKING HORSE

Section 5.1 GENERAL: The Racking Horse is a gracefully built, good-looking mount with a long, sloping neck, full flanks, flat smooth legs, and finely textured hair. Compared with most others, the Racking Horse is small to medium in size, averaging around 15 2 hands in height, and approximately 1,000 pounds in weight. Colors include sorrel, chestnut, black, roan, white, bay, brown, grey, yellow, dun, palomino, buckskin, champagne and cremelo. In some horses, the “rack” is considered to be an artificial gait but to the true Racking Horse, this gait comes just as naturally to him as walking or striking a bold trot to most other horses, therefore requiring no special training to perform his graceful, smooth gait. For years, the Racking Horse has continued to work his way from the farms and plantations and the days of the circuit riders to become one of the most desired show horses of our day. The answer to a beginning rider’s prayer, the Racking Horse is a horse that is kind to humans, smooth tempered, with a four-beat action, which creates

a comfortable shock-absorbed ride. The “rack” is often called the “single-foot” because a single foot strikes the ground at a time. At a rack, the horse should display style, speed and action. The Racking Horse’s natural friendliness and easy-going disposition have made it a favorite with horse show fans and riders alike. His years of performing farm chores have resulted in a docile and intelligent horse of many great qualifications

Section 5.2 CONFORMATION: The desirable points of conformation of the Racking Horse are:

- General Character:** Gentle, intelligent, affectionate
- Color:** Sorrel, chestnut, black, roan, white, bay, brown, grey, yellow, dun, palomino, buckskin, champagne and cremelo
- Markings:** FACE: star, strip, blaze, snip, bald. LEGS: coronet, fetlock, sock, stocking BODY: Sometimes has white markings
- Head:** Intelligent and neat
- Eyes:** Bright
- Ears:** Well-shaped and pointed
- Nostrils:** Prominent and open
- Neck:** Long, graceful
- Shoulders:** Well-muscled, sloping
- Legs:** Slender, well boned
- Feet:** Sound and ample size to challenge lameness
- Tail:** Long and full, infrequently white, often flaxen
- Size:** Average height is 15.2 hands. Average weight is 1,000 pounds.

ARTICLE VI

BREEDERS’ DIVISION

Section 6.1 GENERAL BREEDERS’ COMMITTEE:

The Breeders’ Division is responsible for implementing those requirements of the Articles of Incorporation and the Bylaws of the RHBAAs pertaining to collecting, recording, and preserving the pedigrees of Racking Horses, and maintaining a registry thereof, which shall include but not be limited to the right to maintain a stud registry, to register Racking Horses based upon their performance

of the racking gaits, to license commissioners, to register the foals of Racking registered sires and dams, to register the transfer of registered Racking Horses, and to propose rules concerning the breeding of registered Racking Horses. This being the first stated objective of the RHBAA, in all matters where a conflict arises over the allocation of resources, or policy concerning gaits is in question, the interest of the Breeders' Division shall take precedence. This Division shall be headed by a Breeders' Committee chaired by a Vice President elected by and from the Board of Directors.

Section 6.2 REGISTRATION BY QUALIFICATION: Any horse, regardless of age, not eligible to be registered by birth, meeting the performance requirements must be personally inspected and approved by a qualified Commissioner designated by the RHBAA to determine that the horse performs the rack as defined in Section 8.8 of the Bylaws in order to be registered as a Racking Horse. If such horse meets the qualifications, he may be registered on the books of the RHBAA upon the payment of the required fees, being \$50.00 for a member of the RHBAA and \$100.00 fee for a nonmember. All horses foaled subsequent to December 31, 1993 must be blood typed in accordance with the requirements of the RHBAA (but not the sire and dam of said horse) in order to be qualified for registration hereunder. A horse eligible to be registered under 6.8 shall not be eligible for registration by qualification. Horses with animated hock action shall not be acceptable for registration. If the Rules Enforcement Committee, after investigation and hearing, determines that a horse approved by a Commissioner for registration was so approved despite an obvious disqualification, it may cancel such registration. The Commissioner registering such horse shall be investigated and a hearing shall be conducted by the Rules Enforcement Committee to determine whether cause exists to revoke such Commissioner's license.

Section 6.3 COMMISSIONERS QUALIFICATIONS: Persons selected as Commissioners shall be responsible for evaluating the performance of horses for possible registration of such horses as Racking Horses in the official registry of the RHBAA. Persons selected to serve as Commissioners may be of either sex and

must be at least 21 years of age, must have been a member of the RHBAA for at least one year, must be knowledgeable about horses in general and well versed in the fundamental characteristics of the Racking Horse. It is imperative that each Commissioner observe and inspect each horse to determine that it is eligible to be performance registered and be able to determine the age of a horse through visual inspection of the horse's teeth; and that each Commissioner record proper, complete and accurate identification of a horse's markings on the Application for Registration, enabling the proper marks of identification to become a permanent part of a horse's registration papers. Persons meeting the above qualifications and desiring to be selected as a Commissioner shall complete and submit the application to the Breeders' Committee along with the annual licensing fee determined by the Board of Directors. Designation as a Commissioner is a privilege, not a right, bestowed by the Breeder's Committee according to procedures formulated by it and the Board of Directors, to individuals whose equine expertise and personal character merit the honor. An individual's conduct and ability as a Commissioner is subject to continuous Breeders' Committee review.

Section 6.4 AGE OF HORSES AS SHOWN BY TEETH

One Year



The upper nippers appear first, their forward edges coming through the membrane of the gums when the foal is about one week old; the lower nippers following a few days later. At about five weeks of age the dividers appear, and the corners are first visible at eight to ten months. The drawing above shows the appearance of the lower incisors at about one year after birth. Observe that the nippers and dividers are slightly worn, and by the cut below, that the corners are not yet in contact when the mouth is closed.

Two Years



At about two years of age it will be seen that the nippers are worn smooth all around; the groove through the crown that was visible at the age of one year having disappeared. The dividers are also considerably worn. The corners are well grown, the gums receded slightly from their base, and they have been in contact for three months or more, already showing some little wear along the forward edge.

Three Years

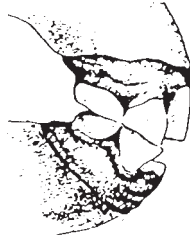

At about two-and-a-half years of age the foal teeth begin to be replaced by the adult or permanent ones. Usually, the upper nippers are shed first and the lower ones a little later. At three years of age the appearance of the mouth is apt to be about as shown above. The dividers and corners are much worn, and are considerably smaller at the base than at the crown. All the permanent nippers are through the gums, the upper ones more developed than the lower, and may be about as shown below, or even sufficiently grown to meet in contact when the mouth is closed.

Four Years



At the age of four years, the permanent nippers and dividers, above and below, have grown out, and are already considerably worn, as shown by the drawing above. All of the old corners are usually remaining at this age, but will soon give way to the permanent ones. They are much worn and appear small in size compared with the new teeth, somewhat as shown below. At about this age, the tusks may begin to appear.

Five Years



By the time the animal is five years of age, as illustrated above, the permanent corners will have grown out level with the nippers and dividers, and will likely show some little wear. The nippers are worn almost level, but retain long and narrow cavities or cups, while the dividers present much the same appearance. In males, the tusks will likely be well formed by this time.

Six Years



At this age the nippers are apt to be worn entirely level, but may sometimes retain a little of a cup. Usually there are still shallow cups in the dividers, but these may in some instances be worn level also. The corners are now considerably worn, and the nippers and dividers are slightly more oval in form. The front, or face, of the nippers as seen by parting the lips, is apt to present a whiter appearance than at five years, due to the wearing away of the yellowish cement.

Seven Years



Nine Years

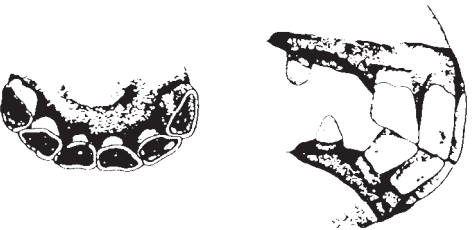

Eleven Years



Thirteen Years



Fifteen Years

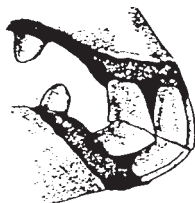

Seventeen Years

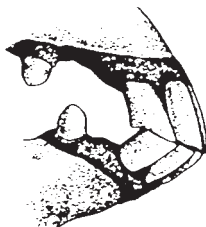

Nineteen Years



Observing the mouth of a horse at this age, it will usually be seen that the distance across the crown of the nippers from front to back is equal to or even greater than their width. The central enamel will, as a rule, have disappeared from the upper dividers, and the corners show a tendency to draw or point inward. The latter, however, may also be observed in a lesser degree at earlier ages. The upper corners usually retain their notch, produced by uneven wear, as shown below, but this is apt to disappear soon, as the angle of contact will be changed as the teeth become more protruded.

Twenty-One Years

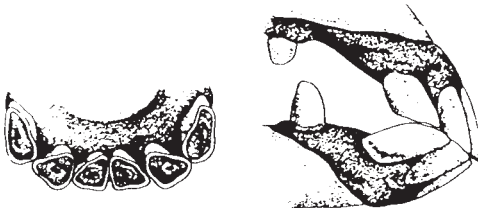

The characteristics of an old mouth are now observed in all particulars, though sometimes there is much irregularity, and some of the teeth may be overgrown and unevenly worn. The jaws are thin and narrow, and the teeth are protruded forward so that they come in contact at an abrupt angle, and the notch in the upper corner has not disappeared. Owing to this position of the teeth, the corners usually present an elongated worn surface from front to back, as show above.

Sub-Section 6.5 HEAD MARKINGS

STAR



STAR AND SNIP



STRIP



BROKEN STRIP



BLAZE



BALD



Sub-Section 6.6 LEG MARKINGS

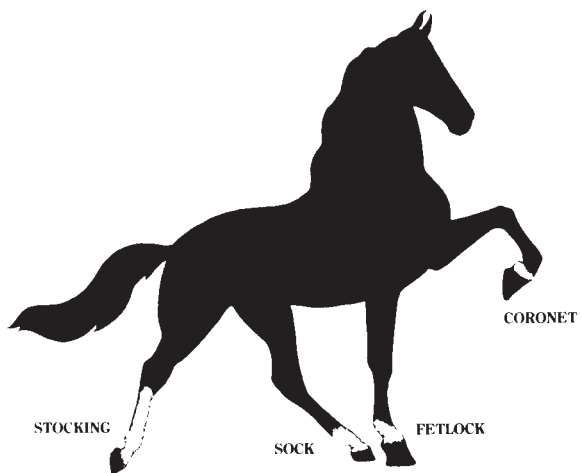

Sub-Section 6.7 NOMENCLATURE

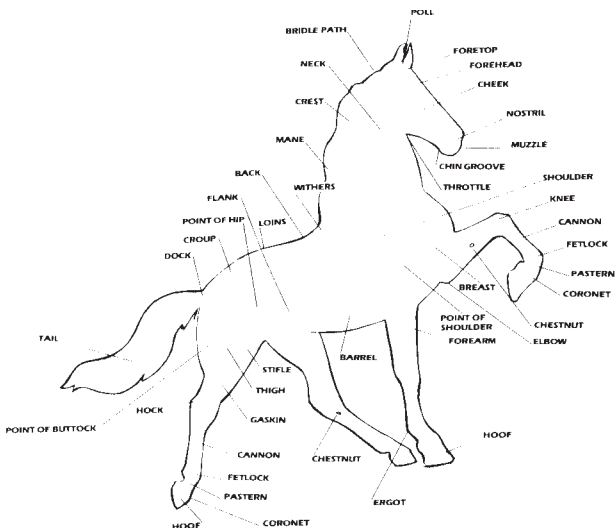

Section 6.8 REGISTRATION BY BIRTH: The foal of a registered sire and dam is automatically eligible for registration without the aid of a qualified Commissioner, so long as the owner of such foal completes all necessary registration forms, including identifying all markings of a foal and providing all other required information as indicated on such forms, and sends them along with the required registration forms to the RHBAA. Forms for registration may be secured from the RHBAA headquarters upon request. Horses with animated hock action shall not be acceptable for registration.

Section 6.9 LEAD LINE PONIES REGISTRATION: Lead Line Ponies are not required to be registered for Racking.

Section 6.10 REGISTRATION APPLICATIONS

- (a) **REGISTRATION BY QUALIFICATION:** Persons desiring to qualify a horse for registration not eligible by birth must

complete application for registration and submit it to a licensed Commissioner with the proper fee. Upon receipt of application and fee, Commissioner shall, within 5 days, forward completed application and fee to the Racking Horse Breeders' Association of America office.

- (b) Registration application for horses sired by a registered Racking Horse stallion out of a registered Racking Horse dam must have the name and registration numbers of both sire and dam on the application in order to be registered. The signature of the owner at time of service (or, if owner is deceased or incapacitated, the signature of his legally authorized representative at such time) is necessary to complete the application.
- (c) Owners of registered Racking Horse Stallions are required to provide a notice within 30 days of the gelding of such stallion, setting forth the date on which the stallion was gelded.
- (d) Owners are required to notify the RHBAA within 10 days of the death of a registered Racking Horse, setting forth the date of death.
- (d) All applications for registration must be typed or printed in ink. These applications become an important part of the records of the RHBAA. Therefore, applications must be clean, neat and legible. Applications with words marked through, erasures, and unsightly appearance will not be accepted. Papers returned for completing or correction more than once will be subject to a "Not in Order Fee."

Section 6.11 STALLION BREEDING REPORTS: Stallion reports cover the period from October 1 through September 30 of each year. The report must be in the RHBAA office prior to 5:00 pm (C D T) on October 15 of each year (If October 15 falls on a Saturday or Sunday, the filing period will be extended until 5:00 p m of the following Monday). It is the responsibility of the stallion owner or his authorized agent to see that the form is in the office by this deadline. The stallion report must be in the Association office before any foals of the breeding year will be registered. In the event the stallion owner fails to comply with these requirements, the mare owner may prove parentage by blood typing of sire, mare and foal for registration purposes. The report shall list all mares bred, by

their registered names and numbers, as well as last breeding date. All Registration Applications must include the preprinted stallion report number which documents the crossing of the foal's sire and dam. A penalty in an amount to be determined from time to time by the Board of Directors will be assessed in the event of a late filing. Failure by any stallion owner to comply with the foregoing requirements could result in such stallion owner's loss of privileges in the Association.

(a) A commission Registered Racking Stallion which has serviced mare(s) will have 60 days from the issue date of the certificate of registration for said stallion in which to file a stallion report with the RHBAA. Failure to file a stallion report within the 60 days of the issue date will result in a late penalty in the amount of \$50.00. Should you own a mare that has been registered Racking but was not registered at the time of service and was serviced by a Registered Racking Stallion, you will have 60 days from the issue date of the certificate of registration for said mare in which to have the mare added to the stallion report on file in the RHBAA office. Failure to have the owner of the sire add the mare within 60 days will result in a late penalty in the amount of \$50.00.

Section 6.12 REGISTRATION FEES: Each Member will be entitled to register one foal free each year out of a registered Racking Horse mare by a registered Racking Horse stallion, within six months of the foaling date, whether bred or purchased, provided transfer fee is paid. All registration and application fee amounts, including late fees, shall be set by the Board of Directors.

Fees as June 1, 2001
(Subject to Change)

Registered within 6 months of foaling

Active Member \$20.00

Non-Member \$40.00

Registered after 6 months, but within 12 months

Second year foaled

Active Member \$40.00

Non-Member \$80.00

Registered after 12 months, but within 24 months

Third year foaled

Active Member \$80.00

Non-Member \$160.00

Registered after 24 months, but within 36 months

Active Member \$160.00

Non-Member \$320.00

Registered after 36 months

Active Member \$200.00

Non-Member \$400.00

Section 6.13 FALSE OR MISTAKEN PEDIGREE: In the event that any pedigree is found to be incorrect, it shall be corrected, and if so incorrect or false as to render the horse bearing it ineligible, it shall be canceled even though made in good faith. All requests for corrections shall be made in writing to the RHBAA by the current registered owner.

Section 6.14 CERTIFICATION: It shall be the responsibility of stallion owners to sign all breeders' certificates for servicing stallions. Trainers, handler, agents, lessees or any personnel of a breeding operation may not sign a certificate for a stallion owner unless documentation is received by the RHBAA specifically authorizing the trainer, agent or handler's signature in lieu of the owner's signature. The form of the Stud Book and registration certificate and other routine matters will be as prescribed by the Board of Directors.

ARTICLE VII

FUTURITY BREEDERS' NATIONAL FUTURITY

It shall be the purpose of the Racking Horse Breeders' Association of America to establish a unity of interest and a cooperative relationship with any individual or group dedicated to the promotion of the Racking Horse. The Racking Horse Futurity Breeders' Association shall function as an auxiliary to the RHBAA in such

matters as promoting selective breeding of quality Racking Horses within the Futurity breeding program. It shall further be the purpose of the Racking Horse Futurity Breeders' Association to promote the welfare of all people involved in the breeding of Racking Horses by encouraging selective breeding, and assuring such breeders that their foals may enter competitive shows under the most favorable conditions the Racking Horse Futurity Breeders' Association can promote. The Association shall also encourage the increase of foal classes in sanctioned shows.

Section 7.1 General Provisions: The Racking Horse Breeders' Association of America Futurity will be shown each year in five Divisions of the RHBAA affiliated/sanctioned show immediately preceding the RHBAA Fall Celebration. All colts and fillies shown must be the progeny of stallions and mares that were registered at the time of foaling and that have been previously nominated in the RHBAA Futurity.

Section 7.2 Nomination of Sire: To nominate a stallion in the Futurity it is necessary: (1) that the stallion be registered in the RHBAA Stud Book, and (2) that a fee in the amount determined by the Board of Directors of the RHBAA be paid to the Futurity on or before August 15 of the year the foal is nominated as a weanling with a grace period until August 31 with a late penalty of \$125.00 per nomination.

Section 7.3 Nomination of Dam: To nominate a mare for the Futurity it is necessary:

- (1) that the mare be registered in the RHBAA Stud Book at the time of foaling/and
- (2) that a fee in the amount determined by the Board of Directors of the RHBAA be paid to the Futurity on or before August 15 of the Year in which the foal is eligible for the Weanling Division of the Futurity.
- (3) Application for registration must be in the RHBAA headquarters by August 15 in the year of which the foal is eligible for the Weanling Division.
- (4) The sire and dam must be nominated in the Futurity in the year in which the foal is eligible.

- (5) Colts and fillies will be shown separately, when practical.
- (6) The entries in this division will be shown in hand.
- (7) All entries are subject to blood typing for parentage verification.

Section 7.4 Eligibility of Weanlings: In order for a foal to be eligible to show in the Weanling Division of the Futurity, the following conditions must be complied with:

- (1) The sire and dam of the foal must be registered in the RHBAA Stud Book at the time of service.
- (2) A fee in an amount determined by the Board of Directors of the RHBAA must be paid to the Futurity on or before June 30 of the year eligible and nominated.
- (3) Application for registration must be in the RHBAA headquarters by August 15 in the year of which the foal is eligible for the Weanling Division.
- (4) The sire and dam must be nominated in the Futurity in the year in which the foal is eligible.
- (5) Colts and fillies will be shown separately, when practical.
- (6) The entries in this Division will be shown in hand.
- (7) All entries are subject to blood typing for parentage verification.

Section 7.5 Eligibility of Yearlings: In order for a colt, filly, or gelding to be eligible for the Yearling Division of the Futurity, the following conditions must be complied with:

- (1) The colt, filly or gelding must have been nominated in the Weanling Division of the Futurity and all conditions and requirements of that Division must have been fulfilled.
- (2) No entry will be allowed to be shown with registration pending.
- (3) A fee in the amount determined by the Board of Directors of the RHBAA must be paid to the Futurity on or before August 15 of the year in which the entry becomes eligible to be shown in the Yearling Division.
- (4) Colts or geldings and fillies will be shown separately when practical.
- (5) The entries in this Division shall be shown in hand.
- (6) All entries are subject to blood typing for parentage verification.

Section 7.6 Eligibility of Two-Year-Olds: In order for a colt, filly, or gelding to be eligible for the Two-Year-Old Division of the Futurity, the following conditions must be complied with:

- (1) The colt, filly, or gelding must have been entered in the Weanling and Yearling Division of the Futurity and all conditions and requirements of those division must have been fulfilled.
- (2) No entry will be allowed to be shown with registration pending.
- (3) A fee in the amount to be determined by the Board of Directors of the RHBAA must be paid to the Futurity on or before August 15 of the year in which the entry becomes eligible to be shown in the Two-Year-Old Division.
- (4) Colts or geldings and fillies will be shown separately when practical.
- (5) The entries in this Division shall be shown under saddle.
- (6) All entries are subject to blood typing for parentage verification.

Section 7.7 Eligibility of Three-Year-Olds: In order for a colt, filly, or gelding to be eligible for the Three-Year-Old Division of the Futurity, the following conditions must be complied with:

- (1) The colt, filly, or gelding must have been entered in the Weanling, Yearling, and Two-Year-Old Divisions of the Futurity and all conditions and requirements of those divisions must have been fulfilled.
- (2) A fee in the amount determined from time to time by the Board of Directors of the RHBAA must be paid to the Futurity on or before June 30 of the year the entry becomes eligible to be shown in the Three-Year-Old Division.
- (3) Colts or geldings and fillies will be shown separately when practical.
- (4) The entries in this division shall be shown under saddle.
- (5) All entries are subject to blood typing for parentage verification.

Section 7.8 Eligibility of Three and Under Country Pleasure: In order for a colt, filly, or gelding to be eligible for the Country Pleasure Division of the Futurity, the following conditions must be complied with:

- (1) The colt, filly, or gelding must have been entered in the Weanling, Yearling, and the appropriate Two and Three-Year-Old Divisions of the Futurity and all conditions and requirements of those divisions must have been fulfilled.
- (2) A fee in the amount determined from time to time by the Board of Directors of the RHBAA must be paid to the Futurity on or before August 15 of the year the entry becomes eligible to be shown in the Country Pleasure Division.
- (3) Colts or geldings and fillies will be shown separately when practical.
- (4) The entries in this division shall be shown under saddle and exhibit the requirements of the Country Pleasure classes.
- (5) All entries are subject to blood typing for parentage verification.

Section 7.9 Fees, Instatement, and Reinstatement of

Eligibility: All payments to the Futurity must be paid to the office of the RHBAA, Decatur, Alabama, and must be postmarked by August 15 to avoid a late fee under a grace period of August 31. Fees and reinstatement as well as instatement of late nominations are available on the current Futurity Nomination Forms obtained from the RHBAA office. Fee amount will be determined by the Board of Directors. All fees must be paid in the year in which the horse will be showing.

Section 7.10 Liability of the RHBAA: No entry is entitled to receive prize funds in any amount greater than the total amount of entry fees paid in. The right is reserved to reject any entry, blood type any entry, and to bar any entry from competition for failure to comply with the conditions of the Futurity.

Section 7.11 Money Equally Divided Among Fillies, Colts and Geldings

- (a) The nominator of the dam of the winning filly foal in the Weanling Division will receive \$50.00. The nominator of the dam of the second place filly foal in the Weanling Division will receive \$25.00.
- (b) The nominator of the dam of the winning colt foal in the

Weanling Division will receive \$50.00. The nominator of the dam of the second place colt foal in the Weanling Division will receive \$25.00.

- (c) The nominator of the sire of the winning filly foal in the Amateur Weanling Division will receive \$50.00. The nominator of the sire of the second place colt foal in the Amateur Weanling Division will receive \$25.00.
- (d) The nominator of the sire of the winning colt foal in the Amateur Weanling Division will receive \$50.00. The nominator of the sire of the second place colt foal in the Amateur Weanling Division will receive \$25.00.
- (e) The value of the Prize Fund of the Futurity each year shall be the total amount of money paid in fees, miscellaneous funds and added donations, and carry over (if any) from the previous year, minus expenses. Each year the specific awards to the nominators of the sires and dams will be deducted before the division of the Prize Funds among the regular divisions of the Futurity.
- (f) The Prize Fund shall be divided equally among the Weanling, Yearling Two-Year-Old, Three-Year-Old and Country Pleasure Divisions.

ARTICLE VIII

SHOW DIVISION

Section 8.1 GENERAL: The Show Division is responsible for implementing those requirements of the Articles of Incorporation and Bylaws of the RHBAA pertaining to the exhibiting and promotion of registered Racking Horses, which includes but is not limited to the establishing of fair and equitable judging, establishing fair and equitable rules concerning the exhibition of Racking Horses, affiliating/sanctioning state and regional shows for the exhibiting of Racking Horses, including competitive events for pleasure classes, promoting the best interests of such shows and sponsoring educational and promotional programs promoting the breed, and promoting the welfare of the RHBAA. The primary purpose of the Show Division is to provide for the exhibition and promotion of Racking Horses to create a market for the breeding, sale and

enjoyment of these Racking Horses. Therefore, in all matters where a conflict arises over the allocation of resources or policy concerning gaits is in question, the interest of the Breeders' Division shall take precedence. The Show Division shall be operated by a Show Committee, a Judges' Committee and an Exhibitor Status Committee, each of which shall be chaired by a Vice President elected by and from the Board of Directors.

Section 8.2 SHOW COMMITTEE: The Show Committee shall be appointed by the Association's Board of Directors and shall be responsible for the production and management of the Spring and Fall Celebrations to be held in the State of Alabama, subject to the approval and requirements of the Executive Committee and the Board of Directors. The Show Committee shall make regular and full reports of its activities and plans for the two horse shows to the Executive Committee or Board of Directors. A Vice President elected by and from the Association's Board of Directors shall chair the Show Committee. The President and Executive Director shall be ex-officio members of the Show Committee, and one of them shall attend all meetings of the Horse Show Committee in order to serve as liaison between the committee and the Board of Directors.

Section 8.3 AGE: For horse show purposes only, a horse shall be considered to be one year old on the first day of January following the actual foal date, with the exception that October and November and December foals may be accepted for classes along with foals of the following year. A horse once shown in an affiliated/ sanctioned event as a weanling, yearling, two-year-old, three-year old or four-year-old, must be exhibited in the subsequent age division as of January 1 of the following year.

Section 8.4 REGISTRATION REQUIRED: Horses competing in the racking classes in shows affiliated/ sanctioned by the RHBAA must be duly registered with the RHBAA (exception: Lead Line Ponies) and must be entered under their full registered names and current registered owner's name. Racking Horse in the Specialty Action Division may be shown with an action device that is in compliance with the HPA Act. Racking Horses in all other divisions

may not be exhibited with tail braces, boots, chains or any other apparatus that would restrict their natural movement.

1. RHBAA registered horse showing in the Specialty Action Division shall not change to any other division of the RHBAA except once a year and before July 1st of that year. The Specialty Action Division classes do not qualify for the World Grand Championship Classes.
2. An affiliated/sanction show by the RHBAA not having a Specialty Action Class would let a Specialty Horse show but not with a action device and this would not count as a change to other division. (2/19/05)

Section 8.5 TACK AND ATTIRE:

1. All tack must be neat and clean and fit the horse correctly.
2. Horses may not be exhibited with tail braces, boots (EXCEPTION: Stretch quarter boots are allowed in all speed classes and versatility timed events), chains (EXCEPTION: Specialty Action Division) or any other apparatus that would restrict the natural movement of the Racking Horse.
3. **Bridles:** Hackamores, martingales and tie downs are prohibited. Bridles should be the type commonly used by Racking Horses, with single reins.
4. **Saddles:** Should be the flat English type. Forward seat saddles are prohibited. Western saddles are prohibited except in designated Western and/or Country Pleasure classes.
5. **Braid:** Should be attached neatly at forelock and mane.
6. **Dress:** Following the tradition of the show ring, it is necessary that the exhibitors be neatly attired for competition. The exhibitor will wear an English riding habit, with the exception of designated Western or Country Pleasure Racking classes. All riding attire shall be neat and properly fitted. A snap brim hat is required for gentlemen. Hats on ladies are optional. Hair must not obstruct back number. Colt handlers may wear a dress shirt and tie.
7. **Breast Straps:** Breast straps may be used, but must be free of any imprinting of names or symbols.

Section 8.6 HEIGHT MEASUREMENT: In those classes designating a determined height of the horse such as 15 2 and Under and Pony, measurement will be made by an official of the show at a time not earlier than one hour prior to the class in which the horse is to be judged. Measurement will be from the high point of the withers to the ground with the horse standing in a natural position

Section 8.7 SHOEING DEFINITIONS and the USDA RULING AS OF JULY 1, 1989: For the purpose of defining "Flat Shod" and "Open Shod," the following descriptions are offered:

A. SHOEING RULES AND REGULATIONS FOR ALL FLAT SHOD DIVISIONS

FLAT SHOD shall be construed as being hoof-to-shoe with no pad being used for any purpose, which shall include corrective shoeing. Weighted shoes are allowed.

- (1) Shoe must not exceed 1/2 inch in thickness and 1 1/2 inches in width with no bare plates or other weight inside the shoe. The caulk must not exceed 1 inch and the shoe must not extend more than 1/4 inch beyond the hoof at the toe.
- (2) Shoeing bands are allowed in all flat shod classes including Pleasure classes except those designated as light shod classes.
- (3) The use of welded clips is prohibited in all flat shod classes. However, clips that are drawn from the shoe itself are allowed.
- (4) No additional weights shall be allowed in or on the hoof other than shoe and nails.
- (5) In all classes designated as light shod, the shoe must not exceed 3/8 of an inch in thickness, nor be wider than 3/4 of an inch. The caulk must not be any thicker than 3/4 of an inch.

B. SHOERING RULES AND REGULATIONS FOR ALL OPEN SHOD DIVISIONS:

OPEN SHOD shall be construed as having pads, which can be flat pads or wedge pads. Weighted shoes are allowed.

- 1. Heel/Toe Measurement:** Toe length must exceed the height of the heel by one (1) inch or more. The length of the toe shall be measured from the coronet band, at the center of the front pastern along the front of the hoof wall, to the ground. The heel shall be measured from the coronet band, at the most lateral portion of the rear pastern, at a 90-degree angle to the ground, not including normal caulks at the rear of the horseshoe that do not exceed an inch in length. That portion of caulk at the rear of the horseshoe in excess of an inch shall be added to the height of the heel in determining the heel-to-toe ratio.

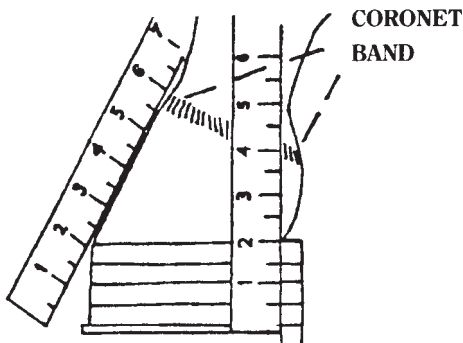

- 2. Pad Measurement:** The amount of pad, or artificial extension, permitted on any horse two years of age or older, will be determined by the natural hoof length. The amount of artificial extension, whether accomplished with pads, acrylics or any other material or combination thereof, must not exceed 50 percent of the natural hoof length. The natural hoof length is measured from the coronet band at the center of the front pastern along the front of the hoof wall, to the distal portion of the hoof wall at the tip of the toe. The thickness of the pad, or artificial extension, shall be measured from the distal portion of the hoof wall at the tip

of the toe at a 90-degree angle to the proximal (foot/h hoof) surface of the shoe.

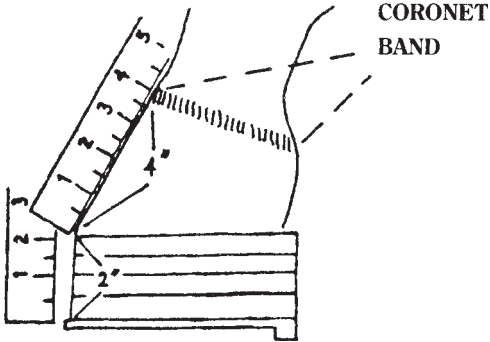

3. **Pads:** Pads shall be made of leather, plastic or similar pliant material.
4. **Shoe Size:** The maximum shoe size is 1 1/2 inches wide and 1/2 inch thick with a turnback for a caulk not to exceed one inch. The turnback is measured from the inside of the fold.
5. **Rubber Foundation:** A rubber foundation used in lieu of a shoe cannot be more than 1/2 inch in thickness.
6. **Half-Rubber Foundation:** A half-rubber foundation used in lieu of half a shoe cannot be thicker than the corresponding half-shoe. Example: with a 3/8 inch thick shoe, rubber cannot be more than 3/8 inch thick. With a 1/2 inch thick shoe, rubber cannot be more than 1/2 inch thick.
7. **Half-Metal Shoe:** A half-metal shoe in front with rubber on the rear half used for the foundation must be in apposition (there can be no gap between the metal shoe and the rubber).
8. **Weight Bearing Surface:** The weight bearing surface of the shoe must be level.
9. **Rockback Pads:** Rockback pads cannot extend below the weight bearing surface (bottom of the shoe).
10. **Lead or Other Weights:** Lead or other weights cannot be attached to the outside of the hoof wall, the outside surface of the horseshoe, or any portion of the pad except the bottom surface within the horseshoe. Pads may not be

hollowed out for the purpose of inserting or affixing weights, and weights may not extend below the weight bearing surface of the shoe. Hollow shoes or artificial extensions filled with mercury or similar substances are prohibited.

11. **Breakover:** The breakover point of the shoe cannot be any further back than the tip of the toe on the natural hoof.

Section 8.8 Gaits: Racking horses shall be shown in each of the three natural gaits: the Show Walk, the Slow Rack, and the Fast Rack, as defined herein:

- (a) The Show Walk is a smooth, collected, slow and easy gait. It is a distinctive four-beat gait displaying both style and grace. The horse is alert and mounted well in the bridle.
- (b) The Slow Rack is a relaxed four-beat gait with both style and action, neither a pace nor a trot. The neck is arched with the head and ears alert. The gait should be straight, smooth and in form at all times.
- (c) The Fast Rack is the same in form as the Slow Rack, displaying style, speed and action. The Fast Rack is faster than either of the other gaits, but form may not be sacrificed for speed.
- (d) Exceptions to the three gaits for Trail Pleasure, Western Pleasure, Style Pleasure, Fine Harness, Juvenile 12 Years and Under, Two-Year-Old, Two-and Three-Year-Old combined, and Style, shall be as determined by Rules promulgated by the Board of Directors from time to time. In each of the three gaits, the horse must be collected and presented well, and the rider must be relaxed and smooth in the saddle. At no time may the horse exemplify a gait with animated hock action. The Racking Horse must exhibit good conformation and be free of blemishes and unsoundness, other than healed permanent scars. The Racking Horse must not exhibit an exaggerated head nod in the Slow Rack or the Fast Rack. It must not exhibit an exaggerated hock action with the rear legs, but its stride should be long and natural. The front leg action must exhibit a curved rolling motion rather than the legs following a straight line, commonly termed "pitching" or "pointing." Abusive treatment and/or training techniques designed to produce an alteration of the gaits shall not be condoned.

Section 8.9 ENTERING RING: All horses shall enter the ring to the right at a Show Walk, unless otherwise specified herein. Horses shall be allowed a three minute gait call after which time the class shall be closed. After the class is closed, no horse shall be allowed entry into the ring. The judge will call for the performance of gaits in the following order: (1) Show Walk (2) Slow Rack (3) Fast Rack. Horses will be worked both ways of the ring in each of the three gaits at least once around the ring. After the initial showing, the horses will be lined up for conformation judging. Saddles must be removed for conformation judging in Championship classes.

Section 8.10 WORKOUTS: In a workout, the judge may call for any or all of the required gaits, the length of which shall be at the judge's discretion. It is at the judge's discretion whether the horses are worked both ways of the ring. Workouts shall be considered a separate class (if less than all participating horses are used in the workout) and horses will be placed consecutively in the workout. A workout may be called for any place or places. If all horses in the class are used in a workout, it shall be considered an extension of the class and not a separate class. (a) For the Spring and Fall Celebration there will be a mandatory split for classes of 26 entries and a mandatory workout at 20 horses.

Section 8.11 CHANGING OF TACK: There shall be no changing of tack after the exhibitor has entered the ring except in the event of breakage of equipment. Minor adjustments are allowed that may be made by the exhibitor momentarily while horses are being reversed in the ring.

Section 8.12 TIME OUTS:

- (a) An exhibitor may request suspension of judging for a period not to exceed ten (10) minutes in total and not more than two (2) times during the performance of a single class, in order to replace a shoe, repair equipment, or rectify an accident.
- (b) Time out is requested by the exhibitor riding to the center of the ring. The ringmaster or steward shall determine the necessity for time out, and shall be responsible for timing

unless an official timer is present.

- (c) Time out shall begin when the exhibitor rides to the center of the ring. In cases when a horse loses a shoe, timing shall begin when the farrier touches the horse or touches the shoe, whichever comes first.
- (d) An exhibitor not involved in a time out may make minor adjustments during a called time out, if the adjustments can be performed without assistance. In this case an exhibitor shall not be charged with a time out.
- (e) The fall of a horse and/or rider shall not disqualify the entry unless it is subject to the bad manners of the horse or exhibitor.
- (f) **UNDER NO CIRCUMSTANCES SHALL TIME OUTS BE CALLED OTHER THAN FOR SHOE REPLACEMENT, EQUIPMENT REPAIR OR TO RECTIFY AN ACCIDENT.**
- (g) If an exhibitor voluntarily removes a horse from competition without first obtaining the permission of the judge or ringmaster, he/ she shall be disqualified from further competition at the show and must forfeit prizes and entry fees.
- (h) Exhibitors shall be excused from the class if they voluntarily dismount without permission of the judge or ringmaster.

Section 8.13 STATE ORGANIZATIONS: The Racking Horse Breeders' Association of America encourages the organization of State organizations to promote their own annual shows in compliance with the Rules and Regulations of the Racking Horse Breeders' Association of America. The Racking Horse Breeders' Association of America will grant honorary membership and will give technical aid and assistance to each State Association organized and operated in compliance with its Rules and Regulations

Section 8.14 STATE CHAMPIONSHIP SHOWS: Only one State Championship Show will be held in each state. The awarding of a State Championship Show will be at the discretion of the RHBAA and will be awarded on the basis of the following criteria:

- (a) The State Association shall be physically able to properly supervise and plan a show that would reflect good quality and taste, and be able to adequately provide services

needed for exhibitors such as adequate stalls, or provisions for same, adequate motel accommodations, etc.

- (b) The State Association sponsoring a State Championship Show must be in good standing with the RHBA. An affiliation/ sanction fee in an amount determined from time to time by the Board of Directors of RHBA shall be paid to the RHBA.
- (c) The State Association shall abide by the RHBA Bylaws, rules and regulations, and shall enforce the current Book of Rules and/or any effected changes that may or may not be included in the current published Book of Rules and Regulations.
- (d) The State Association must be affiliated/sanctioned, by the RHBA. There shall be no more than one State Championship Show affiliated/sanctioned on the same date within a distance of 250 miles.
- (e) It shall be the responsibility of the show management to ascertain that judges are duly qualified and in good standing with the RHBA.
- (f) A State Association may be used as its own benefit or another charitable or civic benefit can be selected at the discretion of the membership.
- (g) Shows designated as State Championship Shows shall be required to maintain three Pleasure divisions. Show management may select the divisions which best suit the needs of a given area.
- (h) Upon a show's compliance with the above requirements, the "logo" Racking Horse Breeders' Association of America may be used on all printing, and a statement may be used indicating "affiliated/sanctioned with the Racking Horse Breeders' Association of America" and may be printed on class schedule and/or programs, etc.
- (i) Failure to comply with the above specifications shall be grounds for the removal, by the RHBA Board of Directors, of all rights to a State Championship Show and the ultimate awarding of all rights to the State Show shall be given to another association within that state's boundaries.

Section 8.15 REGIONAL SHOWS: A Regional Show shall be defined as a show sponsored by a charitable, civic or Racking Association, and, in order to be considered “affiliated/sanctioned,” must comply with all rules and regulations of the RHBAA and must request such affiliation from the RHBAA, and pay the application fee. All rights and privileges shall be extended, including the use of the RHBAA “logo”; however, all personnel shall comply with the same standards as set forth for the State Championship shows, and judges must be members in good standing of the RHBAA and maintain a current license to judge affiliated/sanctioned shows.

Section 8.16 ALL BREED SHOWS: The rules of the RHBAA pertaining to exhibition and showmanship shall be adhered to in every respect and an RHBAA licensed judge shall be used to officiate at all judged Racking events in “All Breed” shows sanctioned by or affiliated with the RHBAA.

Section 8.17

- (a) **THE RACKING HORSE “WORLD CELEBRATION:”** To further implement and provide for the prestige of the Racking Horse as the **GREATEST AND MOST VERSATILE SHOW HORSE IN AMERICA**, an annual World Celebration shall be held in each year in September in Alabama, where an annual “World Champion of the Breed” shall be chosen by a team of qualified judges. These judges to be picked from either the AA or AAA list as defined in section 9.3 (c).
- (b) **THE RACKING HORSE “SPRING CELEBRATION”:** In the interest of the breed and the spirit of section 8.17 (a) an Annual Spring Celebration shall be held in Alabama every April. The show shall culminate with the crowning of the “Spring Celebration Champion of the Breed” chosen by a team of qualified judges.

Election of Judges for Spring and Fall Celebration: The following committees, groups and organizations shall elect Judges from a qualified list provided by the Judges Committee. The list compiled from a questionnaire sent to all judges eligible to judge the respective show and returned to the Judges Committee. The names selected will then be provided to the show committee and those

names placed in a hat and names drawn until the required numbers are drawn according to A, AA, and AAA classification. Each time a judge is selected by the groups, that name will be placed in the hat for the drawing.

General Membership	8
Board of Directors	3
Trainers Association	3
Pleasure Association	3
Amateur Association	3
Futurity Breeders	3
Ladies Auxiliary	3

(9/23/04)

Section 8.18 SHOW AFFILIATION/SANCTIONING:

- (a) Affiliation/sanctioning with the RHBAA is suggested for all shows, whether they are “All Breed” shows or affiliated/sanctioned Racking Horse shows on a local or state level. The “logo” of the RHBAA may be used on all literature and publications when show management has complied with all Bylaws, rules and regulations as set forth in the current book of Rules and Regulations of the RHBAA and Affiliation/Sanction Forms are requested from the RHBAA. All privileges of affiliation/sanction may be extended at the time. State Associations may affiliate/sanction, at their discretion, other breed shows and the State Association name may be used on all printing and publications. A licensed Racking judge must be used at all affiliated/sanctioned shows having more than fifteen racking classes. An affiliation/sanction fee in an amount to be determined from time to time by the Board of Directors of the RHBAA shall be charged to all affiliated/sanctioned shows.
- (b) All affiliated/sanctioned shows will be charged an Affiliation/Sanction Fee to be set by the Board of Directors.
- (c) State Associations do not have the authority to extend

the use of the “logo” of the RHBAA to shows not affiliated/sanctioned with the RHBAA unless prior approval is requested from and granted by the RHBAA.

ARTICLE IX

JUDGING DIVISION

Section 9.1 JUDGES’ COMMITTEE

A Judges’ Committee consisting of knowledgeable horsemen with acknowledged reputations shall be responsible for interviewing applicants and reviewing applicants for judge’s licenses. The Judges’ Committee shall also be responsible for conducting the initial investigation concerning any rule violation or other misconduct of a licensed judge of the RHBAA concerning his/her duties and obligations under these rules as a licensed judge of the RHBAA; and also be the sole initial hearing body authorized to conduct a hearing regarding any such violations, and to determine the appropriate punishment therefore, if any. The Judge’s Committee shall be chaired by a Vice President elected by and from the Board of Directors.

- (a) The word “Judge” shall apply to those individuals who are recognized by the Racking Horse Breeders’ Association of America and hold a current license approved by the Judges’ Committee of the Racking Horse Breeders’ Association of America and have completed all requirements of the Committee.

Section 9.2 APPLICATION AND APPRENTICESHIP

Applicants for judges’ positions must present written qualifications as to their knowledge of the Racking Horse, ability to judge the same, personal honesty, integrity, and must enjoy a good reputation among their peers. Upon an approval by the Judges’ Committee, an applicant is then required to pass a written examination and apprentice under three licensed judges in three affiliated/sanctioned shows. If after an apprentice passes the written examination and serves at three affiliated/sanctioned shows, there is reason to believe the apprentice is qualified, a license may be issued to the applicant. A licensed judge is required to be a Member of the RHBAA in good

standing. Designation as a Racking Horse Breeders' Association of America-approved judge is a privilege, not a right, bestowed by the Judge's Committee according to procedures formulated by it, to individual whose equine expertise and personal character merit the honor. An individual's ability and conduct as a member, exhibitor, and judge must be exemplary and are subject to continual review.

(a) Admission to the Program:

1. Request to enter the Judge's Apprentice Program must be submitted in writing to the Judges' Committee and received prior to December 31st of the year to be considered for acceptance for the next year.
2. When the Judges' Committee receives the request, the applicant will then be mailed an application. This application is to be completed and returned to the Judges' Committee within fifteen (15) days. When the application is received, all persons listed as references will be mailed a recommendation form. This form must be completed and returned to the Judges' Committee.
3. The Judges' Committee will review all applications at its meeting during the Winter Membership Meeting of each year. The Committee will decide which applicants meet the requirements to take the examination necessary for acceptance into the Apprentice Program for the year.
4. Applicants not selected for the current year will have to repeat the above outlined procedure the following year or any year thereafter.
5. The Judges' Committee will review all applications at its meeting during the annual Winter Membership Meetings of each year. The Committee will decide on which applicants will be accepted to the program for the current year.

(b) Requirements: To be eligible for admission to the Apprentice Judges' Program, the applicant must meet the following requirements:

1. Must be at least 21 years of age.
2. Must have been a member in good standing of the Racking Horse Breeders' Association of America for a minimum of three (3) full consecutive years immediately preceding the year of his application.

(c) **Acceptance to Program:** Upon the acceptance of a candidate, the following will take place:

1. All potential candidates must pass the written examination in order to be accepted into the Judge's Apprentice Program. The selected Applicants will be notified of a time and place to take the written test during the annual Winter Meetings.
2. After passing the written exam, the applicant is accepted into the Judge's Apprentice Program at which time a \$25.00 payment of the \$50.00 program fee is required. Only shows affiliated/ sanctioned by the Racking Horse Breeders' Association of America shall be counted, and in the event the apprentice cannot attend one of the assigned shows, he/she must so notify the Judges' Committee in advance and receive proper instructions as to what show he/she may substitute. After each class, the apprentice judge must compare his/her selections with those of the licensed judge under whom the applicant apprentices. At the completion of the show, the judge must communicate to the judges' committee a recommendation regarding the apprentice judge.
3. The Apprentice must turn his/her judge's cards in to the judge under whom he/she is apprenticing at the end of each class and compare his/her selections with those of the licensed judge under whom they are apprenticing. At the completion of the show, the judge must communicate to the RHBAA Judges' Committee a recommendation regarding the Apprentice Judge.
4. The Apprentice must receive the approval of all judges under whom he/she apprentices. In the event that some of the evaluations are negative, the Judges' Committee, after evaluation, may require that additional shows be apprenticed or drop the apprentice from the program.
5. All requirements must be completed within 12 calendar months from the date the candidate is admitted to the Apprentice Program. If this is not accomplished, the candidate must wait at least on year before he/she may again apply for the Apprentice Program.
6. Upon Successful completion of the Apprentice Program, the balance of \$25.00 is due. An "A" license will be issued following the annual Winter Meetings.

Section 9.3 JUDGES CLASSIFICATION SYSTEMS

(a) Judges' licenses granted by the Racking Horse Breeders' Association of America shall be as follows:

"A" License: Upon completion of the apprentice program, a newly licensed judge will be issued an "A" license

"AA" License: To be eligible for this license, a judge must have held an "A" license and judged a minimum of four (4) affiliated shows. (9/23/03)

"AAA" License: To be eligible for this license, a judge must have held an "AA" license for three (3) years and must have judged a minimum of five (5) shows during this period, of which two (2) shows were either multi-day shows or State shows. He/she will hold their license as long as he/she meets the requirements for licensing each year.

(b) If a judge has not judged two affiliated RHBA shows in a period of three (3) years, he/she must petition the Judges' Committee for relicensing.

(c) To be eligible to judge the Spring and Fall Celebration, a judge must hold an "AA" or "AAA" license.

(d) Once a judge feels that he/she has met the requirements to advance to the next level of a Judge's License, he/she must submit a request to the Judges' Committee to advance. The Committee shall review the Judges' file and make a final ruling on the Judge's Classification.

(e) A Judge will remain under continuous review of the Judges' Committee. All letters pertaining to his/her judging as well as formal protest, and any evaluation forms sent in on judges, will be kept in their respective files for review by the Committee. Upon receiving three (3) letters of complaint on a judge, the Judge will be required to appear before the Committee for review for possible disciplinary action. All formal protests concerning rule violations will be addressed at the earliest scheduled meeting of the Committee.

(f) All Judges will be required to attend the annual Judges Meetings two (2) out of every three (3) years.

Section 9.4 REQUIREMENTS FOR JUDGING

- (a) A judge serves his/her own conscience in keeping with Rules of the Racking Horse Breeders' Association of America.
- (b) A judge must dismiss any horse whose actions threaten or endanger other exhibitors.
- (c) An entry may at the discretion of the judge(s) be excused from the ring for any infraction of noncompliance of the RHBAA Rulebook. The entry shall be eligible to show in succeeding qualifying class if the problem can be corrected.
- (c-1) Serviceable Soundness For Horseshow Purpose: All horses shown at a show must be serviceable sound. The official veterinarian's decision, if requested by the judge, as to serviceable soundness of a horse shall be final. If the veterinarian is not immediately available or called on, the Judges decision as to serviceable soundness of a horse shall be final.
- (c-2) Blood Rule as Follows: A show official shall inspect each horse on the lineup. Any horse which displays evidence of blood in non-compliance with this rule, will be brought to the judges' attention. Cause for dismissal is as follows: Visual observation of blood that has adequate mass to flow or depart from its point of origin.
- (d) Acceptance of remuneration and expenses for judging at a show shall not affect the amateur status of a judge.
- (e) A judge shall not be required to give his/her reasons for a tie to any exhibitor, or spectator, or person other than an RHBAA authorized official.
- (f) A judge's decision represents his/her own individual preference in accordance with the Rules and Regulations of the Racking Horse Breeders' Association of America.
- (g) Failure of a judge to attend a show to which he/she is committed to perform his/her duties and to officiate in the classes to which he/she is assigned shall constitute cause for disciplinary action by the Judges' Committee, unless such absence was without justification. (Ex: sickness or accident en route to the show)
- (h) In every instance, a judge shall conduct him/herself in a manner befitting the Racking Horse Breeders' Association

of America and any action that would discredit the RHBAA shall be considered a violation of the moral code of a judge.

- (i) In no case shall a judge, duly licensed by the Racking Horse Breeders' Association of America to officiate at an affiliate/sanctioned show, advertise his/her services to the general public in any media such as an official publication of the Breed, or one representing the Racking Horse in general.
- (j) A licensed judge may not officiate at any show that is not affiliated/sanctioned by the Racking Horse Breeders' Association of America without written permission from the Racking Horse Breeders' Association of America.
- (k) A judge may excuse any entry that is being shown out of classification.
- (l) Telephone calls or other contact from trainers, exhibitors, etc. to a judge with regard to a tie or ties at a forthcoming show are to be reported to the Rules Enforcement Committee for appropriate action.
- (m) A judge, by accepting an invitation to officiate a show, assumes a responsibility to protect show management by excusing from the ring all horses suspected of being in violation of the Rules and Regulations of the Racking Horse Breeders' Association of America.
- (n) It is the responsibility of a judge to report any Rule violation to the Rules Enforcement Committee.

Section 9.5 ANNUAL RELICENSING OF JUDGES

- (a) **Relicensing Procedure:** All judges must be relicensed annually. The procedure for relicensing shall be as follows:
 - 1. The individual must be a member of the Racking Horse Breeders' Association of America.
 - 2. The judge must submit a request for license renewal. The Judges' Committee shall mail a Request for Relicensing Form to each licensed judge annually, no later than the first day of December. This Request must be completed and returned to the Committee no later than the last day of January if the judge is to be relicensed for the coming

year. Exceptions to this requirement shall be approved by the Judges' Committee.

- (b) A judge must attend the annual Judges Clinic a **MINIMUM** of 2 out of every 3 years. Any judge not attending the annual Clinic must produce evidence in writing of his/her inability to attend the Clinic, and have his/her absence excused by the Judges' Committee prior to his/her relicensing.
- (c) The payment of annual fee of \$35.00 must be received by the Racking Horse Breeders' Association of America by January 31.
- (d) Agreement by the Judge to abide by the Code of Professional Ethics for Judges licensed by the Racking Horse Breeders' Association of America.
- (e) Any Judge who has had any negative reports filed against him/her will be reviewed by the Judges' Committee prior to relicensing.
- (f) The Judges' Committee, with the approval of the Racking Horse Breeders' Association of America Board of Directors, may require a candidate to appear for a personal interview before a new license is granted.
- (g) Any Judge not complying with the above may not be licensed.
- (h) **Testing:** The Judges' Committee shall revise the written examination annually. The written examination shall be given once per year at the annual Judges Clinic. In the event the candidate fails to pass the written test, he/she must wait a period of one year to be re-tested. If the written test is failed for the second time, the candidate will be dropped from the Program and must wait a period of two years to re-apply.
- (i) **Fees:** The fee for licensing an apprentice judge shall be \$50.00. One-half of that fee shall be paid at the time the candidate is admitted to the Apprentice Program, to be used to cover the expenses of processing the candidate. The remaining \$25.00 shall be paid at the time of taking the written test.

Section 9.6 LICENSE DENIAL, REVOCATION, SUSPENSION

All pertinent facts concerning a licensed judge charged with unethical conduct or rule violation or whose license has been denied shall be immediately placed by the Judge's Committee before the Racking Horse Breeders' Association of America Rules Enforcement Committee for investigation and appropriate action, if required.

- (a) A judge must understand that his/her license to judge sanctioned Racking Horse shows may be denied, revoked, or suspended for the following:
 1. Acts of fraud, deceit or misrepresentation in obtaining the license
 2. Acts of gross negligence, incompetence, or misconduct in carrying out the duties or responsibilities of a licensed judge
 3. Willful disregard of the Rules and Regulations and requirements applicable to a licensed judge as set forth by the Racking Horse Breeders' Association of America Board of Directors

Section 9.7 CODE OF PROFESSIONAL ETHICS FOR LICENSED JUDGES

- (a) The objective of this Code of Ethics is to provide for professional, equitable judging by licensed judges of the Racking Horse Breeders' Association of America through the acceptance and adherence to those Rules and Regulations established by the Racking Horse Breeders' Association of America that are necessary to provide benefit to the general public, and to promote growth of the Racking Horse industry.
- (b) A Judge of all affiliated/sanctioned shows will be expected to dress in a manner that reflects good taste upon the Racking Horse industry. Attire for evening performances shall be coat and tie with appropriate slacks or dress designated by show management. Minimum dress for afternoon performances at any affiliated/sanctioned show will be shirt, tie and appropriate slacks or dress.

- (c) Designation as a RHBAA-approved Judge is a privilege, not a right, bestowed by the Judges' Committee according to procedures formulated by it, to individuals whose equine expertise and personal character merit the honor. An individual's conduct as a member, exhibitor and Judge, and his/her ability, must be exemplary, and is subject to continuous Judges' Committee review.
- (d) The term "Licensed Judge" connotes competence, fair dealing and high integrity resulting from adherence to the Bylaws and Rules of the RHBAA and to idealistic and high moral conduct. No inducement of profit or personal gain can ever justify departure from this ideal or from the Pledge contained herein.
- (e) Judges Conduct: Judges are prohibited from socializing or conducting personal business at any time, in any manner, with exhibitors, owners, trainers, or their representatives, on or away from the show grounds, including but not limited to all RHBAA sponsored events, during the duration of any RHBAA show at which they are officiating. The only exception shall be to attend the Board Meeting or appropriate RHBAA Committee meeting for the duration of the meeting only. It is the responsibility of a judge to conduct himself/herself in a manner befitting the RHBAA and its membership. It is also the responsibility of a Judge to avoid situations that may be negatively perceived. If it is determined that a Judge has violated this policy, the Judges Committee shall consider revocation of said Judge's RHBAA license.

Section 9.8 JUDGE'S PLEDGE

A licensed Racking Horse judge shall be bound by the following pledge:

I pledge myself to professionalism in the execution of the responsibilities as a judge through my efforts and through the mutual efforts of my colleagues, and by any other proper means available. I pledge myself to seek and maintain an equitable, honorable and cooperative association with fellow judges and all others who are concerned with the improvement, betterment and growth of the Racking Horse industry. I pledge myself to

place honesty and integrity above all else, to pursue these goals with study and dedication, to the end that service to the Racking Horse industry be maintained at the highest possible level. I pledge myself to comply with Rules of the Racking Horse Breeders' Association of America.

ARTICLE X

EXHIBITORS STATUS

Section 10.1 EXHIBITOR STATUS COMMITTEE:

The Exhibitor Status Committee shall be composed of five members and chaired by a Vice President elected by and from the Board of Directors of the RHBAA. Three members shall be appointed by the Board of Directors of the RHBAA and two shall be appointed by the Amateurs' Association. For so long as there exists a Racking Horse Trainers' Association, two of the three appointments to the Exhibitor Status Committee to be made by the Board of Directors of the RHBAA shall be members of the Racking Horse Trainers' Association. The Exhibitor Status Committee shall be primarily concerned with the status of all exhibitors at shows affiliated/sanctioned with the RHBAA (i.e.: amateurs, professionals, juveniles). The Committee has the responsibility of interpreting and policing the Bylaws and Rules of the RHBAA concerning exhibitors' status. It shall issue and renew Amateur Show Cards, Professional Show Cards and Juvenile Show Cards according to the Bylaws and the Rules of the RHBAA.

Section 10.2 DEFINITION OF STATUS

- (a) The rules of the RHBAA shall apply to all exhibitors participating in any RHBAA sanctioned event.
- (b) The term "exhibitor," for purposes of explanation, shall refer to the rider, owner or lessee of a horse when entered in a class. An exhibitor may not serve as a judge, ringmaster, steward or manager at a show at which they participate.
- (c) **Amateur:** A person shall be considered an Amateur for all competitions conducted under the Rules of the Racking Horse Breeders' Association of America who, after his/her

eighteenth birthday has not engaged in any activities which would make him/ her a professional as stated in Section 10.5 (a).

- (d) **Professional:** A person becomes a Professional for horse show purposes if he/she engages in any of the activities, after his/her eighteenth birthday as stated in Section 10.5 (a).
- (e) **Juvenile:** A Juvenile for all competition, under the Rules of the RHBA, is a person who has not reached the age of 18, (Exception: Juvenile who turns 18 after January 1, who chooses option to show as an Amateur [Section 10.6 (b)].)

Section 10.3 EXHIBITOR SHOW CARDS

- (a) Every person competing in an RHBA affiliated/sanctioned class must possess an Exhibitor Show card issued by the Racking Horse Breeders' Association of America. Show management must inspect this card at any show entered and list rider's Exhibitor Show Card number on entry sheet. Application for an Exhibitor Show Card shall be made on a form provided by the Racking Horse Breeders' Association of America.
 - 1. There shall be an annual fifteen (\$15.00) fee for said Exhibitor Show card; after March 15, fee will be \$25.00.
- (b) All applications for Exhibitor Show Cards and all requests for renewal thereof shall be presented to the Exhibitor Status Committee for approval. Exhibitor Show Cards will be issued by the Racking Horse Breeders' Association of America on an annual basis only after said approval. A decision by the Racking Horse Breeders' Association of America not to issue an Exhibitor Show Card may be appealed to the Exhibitor Status Committee at the Racking Horse Breeders' Association of America office within 15 days of notification.
- (c) The procedure for appeals from decisions denying issuance of Exhibitor Show Card or for revocation of Exhibitor Show Card will be the same as those for hearings before the National Rules Enforcement Committee as set forth in Article XVI, Section 16.4 with a final right of appeal to the

Racking Horse Breeders' Association of America Board of Directors.

- (d) All Exhibitor Show Card holders will be reviewed annually at the time application for renewal is made; said application to be on a form supplied by the Racking Horse Breeders' Association of America and returned to the RHBAA along with applicant's fifteen dollar (\$15.00) fee as above provided.
- (e) Upon request by the Racking Horse Breeders' Association of America, the Exhibitor Show card will be immediately surrendered, pending hearing before the Exhibitor Status Committee for revocation decision. Additionally, when an individual, for any reason, becomes ineligible for Exhibitor status, he or she shall promptly return the Exhibitor Show card to the Racking Horse Breeders' Association of America, whether or not request is made for it.
- (f) An individual may be subject to possible disciplinary action under the general rules of the Racking Horse Breeders' Association of America for refusal to surrender an Exhibit Show card upon Racking Horse Breeders' Association of America request, retention of an Exhibitor Show Card after an individual becomes ineligible for Exhibitor status, or for participation in a class while ineligible for Exhibitor status.

Section 10.4 AMATEUR SHOW CARD: Every person competing in an Amateur class must possess an Amateur Show card issued by RHBAA. Show management shall inspect this card at any show entered and list rider's Amateur Show Card number on entry sheet. Application for an Amateur Show Card shall be made on a form provided by the RHBAA.

(A) Amateur: A person shall be considered an Amateur for all competition conducted under the rules of the RHBAA who, after his/her eighteenth birthday, has not engaged in any activities which would make him/her a professional.

(B) Amateur Owned and Trained:

1. In all cases, with no exception, ownership on the registration papers must be in the name of the exhibitor. Ownership by a corporation or company is prohibited. Co-owners are permitted but must be of the immediate

family members as described in Section 10.6 (a), of the current Rule Book.

2. The horse may not have been in a professional training barn for any part of the 90 consecutive days immediately prior to exhibition.
3. The Amateur Owned & Trained horse shall not be assisted in a physical manner with the preparation, training or exhibition from a professional trainer or an agent thereof for a period of 90 consecutive days prior to the show. However, transportation to and from a show by a professional or an agent thereof is not prohibited.
4. Violation of any of the rules regarding the Amateur Owned and Trained Division will apply to the exhibitor, professional trainer or an agent thereof, and horse involved. These violations will carry a C Violation penalty.

(C) Owner-Trainer: An owner-trainer shall be considered an Amateur provided the rules regarding an Amateur are met by the exhibitor. An individual shall not be required to be classified as a Professional solely because the individual trains his/her own horse.

Section 10.5 PROFESSIONAL SHOW CARD: Every person designated as a Professional according to the Rules of the RHBA must possess a Professional Show card issued by the RHBA. Show management shall inspect this card at any show entered and list rider's Professional Show card number on entry sheet. Application for a Professional Show Card shall be made on a form provided by the RHBA.

- (a) Under these rules, a person and/or exhibitor is a professional if he/she is 18 years old or older and receives income, pay or benefits of any kind for training and/or showing horses (breeding is excluded) not owned by him or her, or if he/she holds himself/herself out to the general public as a "trainer."
- (b) Relative of a professional: Any member of a professional's immediate family who is 18 years old or older, who is not otherwise a professional under 10.5 (a), and who is living at

home, or who claims the residence of the professional family member as his/her legal residence, or who is dependent on the professional family member for a substantial portion of his/her support, is a professional as to any horse that is not solely owned by said relative. Immediate family member means spouse, child, stepchild, ward, parent, stepparent, brother, sister, grandparent or guardian.

- (c) The Professional Trainers Association shall certify all applicants. Yearly certification is required. Criteria for certification shall be Compliance to the Professional Trainers Code of Ethics. The Professional Trainers Card may be revoked by the RHBAA Status Committee, if the certification on a recommendation by the Professional Trainers Association, is based on a failure of the professional to comply with the associations code of ethics.

Section 10.6 JUVENILE SHOW CARD: Every person designated as a Juvenile according to the Rules of the RHBAA must possess a Juvenile Show Card issued by RHBAA. Show management shall inspect this card at any show entered and list rider's Juvenile Show card number on entry sheet. Application for a Juvenile Show card shall be made on a form provided by the RHBAA.

- (a) **Juvenile:** A Juvenile for horse show purposes is a person who has not reached the age of 18:
 - (1) Senior Juveniles are riders 13 through 17 years of age.
 - (2) Junior Juveniles are riders 12 years of age and under.
 - (3) Lead Line Juveniles are riders 6 years of age and under. Juveniles of these age groups are prohibited from showing stallions in any class designated as Juvenile or Pleasure. This includes all divisions of Racking, excluding Pony classes. In no case may the dependent juvenile child of a Professional be allowed to exhibit in classes designated as Juvenile Owned and Trained.
- (b) A Juvenile who is eligible to show as an eighteen-year-old in the Juvenile Division may decide to show in the Amateur Division. This decision must be made by January 1 of his/

her eighteenth year old show season. Once he/she makes the decision to show in either Juvenile or Amateur Division, he/she must stay in that Division and cannot change.

- (c) **Juvenile Owned and Trained:** Horses must not have been in a professional training barn for 90 days prior to exhibition to be shown in a Juvenile Owned and Trained class.

Section 10.7 AGE OF EXHIBITOR: For show purposes, an exhibitor maintains his or her age as of January 1st of each year throughout the show year.

Section 10.8 CHANGE OF STATUS: Once a person has become a Professional for horse show purposes, he/she shall retain this status until such time as an application is made to the attention of the Exhibitor Status Committee of the RHBAA. Any person who has been a Professional and who desires to be established as an Amateur on the grounds that he/she no longer engages in the activities which would classify him/her as a professional shall notify the RHBAA (Attn: Exhibitor Status Committee) in writing. One (1) year after receipt of said notice he/she may become officially reclassified. A person shall not change status more than twice in a five year period, and a request for change in status shall be considered only upon the Exhibitor Status Committee's receipt of a letter outlining reasons for the change and upon the receipt of the fee set by the Board of Directors.

ARTICLE XI

RACKING DIVISIONS

In a responsible effort to provide family entertainment for the Racking public and in an effort to insure that the breed is properly recognized as the most versatile horse in America, several divisions of Racking are recognized by the Racking Horse Breeders' Association of America. Each division is recognized as an equal counterpart at all affiliated/sanctioned shows with equal emphasis being given to each division.

Section 11.1 TRAIL, FIELD AND PLEASURE DIVISION:

The Trail, Field and Pleasure Division has the purpose of helping members experience the natural abilities of the Racking Horse in its native environment both inside and outside the show ring and to keep sharp the skills of rider and horse under saddle or in harness throughout the year. Lovers of animals, particularly fine horses, will find in the Racking Horse a willing and gentle companion, a provider of hours and years of enjoyment. On the trail, the hunt, in the ring, on the farm or estate, in harness or under saddle, this is the horse to be cared for and enjoyed by every member of the family. This is the horse the RHBAA is dedicated to preserve in its natural state and to promote for the enjoyment of more and more families throughout the country. The Trail, Field and Pleasure Division shall be operated by a Committee chaired by a Vice President elected by and from the Board of Directors of the RHBAA.

Section 11.2 PLEASURE DIVISION

- (a) Horses competing in the Pleasure Division are not eligible to compete in any other division (exception: Sub Section 11.2 (c) below). The Pleasure Division of Racking shall be open only to Amateurs and Juveniles.
- (b) Juveniles may not ride/drive stallions in any of the Pleasure divisions.
- (c) Horses may not cross over from one division of Pleasure to the other with the exception that Trail Pleasure, Country Pleasure and Western Pleasure Division horses may compete in any or all three divisions at the same show. However, any Pleasure horse may show “up” in his division if a class is not provided for him at a particular show (a Style Pleasure horse would go “up” to an Amateur class if no Style Pleasure class were offered).
- (d) Horses competing in any Pleasure division:
 - 1. Trail Pleasure
 - 2. Trail Pleasure Lite Shod
 - 3. Country Pleasure
 - 4. Country Pleasure Lite Shod
 - 5. Western Pleasure
 - 6. Western Pleasure Lite Shod
 - 7. Park Pleasure

8. Show Pleasure
9. Style Pleasure
10. Model (Halter)
11. Pleasure Racking

Racking Horse Breeders' Association of America Approved classes sanctioned by the Racking Horse Breeders' Association of America shall be true pleasure mounts in every sense, and the interpretation of "Pleasure" pertaining to any of the divisions of Pleasure is at the full and total discretion of the judge. Horses may not, under any circumstances, cross over from one division of Pleasure to the other without the express permission of the Racking Horse Breeders' Association of America or as expressly designated by the Rules herein.

- (e) In the Pleasure Division whips, crops, and cross-chain cavessons are prohibited, except that in all Halter or Model classes the handler may use a whip which has a length of no longer than three (3) feet. English or Western spurs are optional. Western tack is permitted in Pleasure Divisions where designated.

Section 11.3 BITTING IN PLEASURE DIVISION: Severe bits must be penalized in the final judging. Shanks over nine and 1/2 inches (9 1/2") are prohibited.

Gag bits without shanks are not allowed. Shanks are measured from the top to the very bottom of the metal, including the rings. Cross-chain cavessons are prohibited.

Section 11.4 TRAIL PLEASURE DIVISION

- (a) The Trail Pleasure horse shall not be required nor expected to maintain qualities such as a high head or high front leg lift, but should be the ultimate of a trail type horse, and should show evidence of being collected in his gaits. He shall stand quietly and back readily, and will be required to perform two gaits: (1) Trail Pleasure Walk and (2) Trail Pleasure Rack. In no instance will speed be considered a factor in judging. He will be flat shod and lightly bitted, but not loose.

- (b) The Trail Pleasure Walk is a true walk in which the rider and his mount are at complete ease. The rein is light and there is no evidence of any strain on the part of horse or rider.
- (c) The Trail Pleasure Rack is considered to be a true four-beat gait (very smooth). It is recognized as being the ultimate for a pleasure horse in which ease of riding and comfort is paramount. There is no evidence of strain on the part of the horse or the rider, and the reins are lightly held in two hands. Speed shall not be considered a factor in judging this division.
- (d) Trail Pleasure horses shall enter the ring at a Trail Pleasure Rack prior to initial judging of the class. Two (2) gaits will be called for, beginning with Trail Pleasure Walk, after all entries have entered the ring prepared for being judged.
- (e) For shoeing requirements refer to Section 8.7 A.
- (f) Trail Pleasure Lite Shod

The same specifications as the Trail Pleasure Division, with the exception that the shoe requirements must follow the Lite Shod rules. Refer to Section 8.7 A(5) of the Rule Book.

Section 11.5 COUNTRY PLEASURE DIVISION

- (a) The Country Pleasure Horse shall be shown with a light rein; both horse and rider must be relaxed and comfortable. He shall not be required to maintain a high head but should be alert in the bridle. He shall not be required to maintain a high front leg lift, but should exhibit a smooth stride behind. The Country Pleasure Horse will be required to perform three gaits: (1) Country Pleasure Show Walk, (2) Country Pleasure Slow Rack and (3) Country Pleasure Fast Rack. The Country Pleasure horse shall stand quietly and must back readily. The tack and dress for Country Pleasure may be either English or Western but not a combination of both. Use of a cavesson is permitted in the Country Pleasure Division.
- (b) The Country Pleasure Show Walk shall be a slow, true four-beat gait. There shall be a smooth stride behind with a natural rolling motion in the front. The Country Pleasure

Show Walk will not have the speed or animation of the Country Pleasure Slow Rack.

- (c) The Country Pleasure Slow Rack shall be a true four-beat gait, distinguished from the Country Pleasure Show Walk. There will be no evidence of strain on the part of the horse or rider. The reins shall be held lightly.
- (d) The Country Pleasure Fast Rack shall be a comfortable, easy-going rack in which speed is not a factor, but easily distinguished from the other two gaits required of this division; there shall be a smooth stride behind and a natural rolling motion up front. The reins shall be held lightly. Any indication of strain on the part of the horse or rider will be penalized.
- (e) The Country pleasure horse shall enter the ring at a Country Pleasure Show Walk prior to initial judging of the class. Three gaits shall be called for, beginning with the Country Pleasure Show walk, after all entries have entered the ring prepared for being judged.
- (f) For shoeing requirements, refer to Section 8.7 A.
- (g) Country pleasure Lite Shod
The same specifications as the Country pleasure Division with the exception that the show requirements must follow the Lite Shod rules. Refer to Section 8.7 A(5) of the Rule Book.

Section 11.6 WESTERN PLEASURE

- (a) The Western Pleasure horse should exhibit qualities needed for ranch or farm work. The horse should work quietly in a smooth gait without excessive action. The head should be a natural set. The horse should be ridden with a loose rein. Reins must be held in one hand and cannot be changed during performance. With split reins, only the index finger is permissible between the reins and at no time should the free hand touch the reins. Exception to this would be the use of Romal reins. When the horse is moving, the rider's hands are clear of horse and saddle.
- (b) Western tack and attire including boots, hat and long sleeved shirt are mandatory. Chaps and spurs are optional. Australian stock saddles are not permitted.

- (c) The judge shall call for a halt on the rail. The horse will stand quietly. On the judge's command, each horse will be asked to back clear of the line-up and execute a 360-degree neck-reined turn (left or right at the rider's discretion). Two gaits will be called: Pleasure Walk and Slow Rack. The horse shall wear a western bridle with no cavesson. No whips are allowed. At no time should silver mounted or embossed equipment count over good working equipment. Braids, martingales, nose bands and tie downs are not allowed.
- (d) The Western Pleasure Walk is a true walk in which the rider and his mount are at complete ease. The rein is loose and there is no evidence of any strain on the part of horse or rider.
- (e) The Western Pleasure Rack is considered to be a true 4 beat gait (very smooth). It is recognized as being the ultimate for a pleasure horse in which ease of riding and comfort is paramount. There is no evidence of strain on the part of the horse or the rider, and the reins are held loosely in one hand. Exception to this would be the use of Romal reins. Speed shall not be considered a factor in judging this class.
- (f) For shoeing requirements, refer to Section 8.7A.
- (g) Western Pleasure Lite Shod

The same specifications as the Western Pleasure Division with the exception that the shoe retirements must follow the Lite Shod rules. Refer to Section 8.7A(5) of the Rule Book.

Section 11.7 PLEASURE RACKING DIVISION

The Pleasure Racking horse shall display a natural head set. Front leg lift shall be less than the Country Pleasure horse yet more than the Trail Pleasure horse. At no time shall a horse breaking level or near level be considered for placement. The horse shall exhibit a smooth natural stride behind. At no time shall a horse exhibiting a deep set, over striding, exaggerated rear stride be considered for placement.

The Pleasure Racking Horse will be required to perform three gaits:

1. Brisk Walk; 2. Slow Rack; 3. Extended Rack.
 1. Brisk Walk: Horse must exhibit a brisk walk, but not a show walk, be alert in the bridle, well collected and controlled.
 2. Slow Rack: Horse must exhibit a slow, smooth, four beat gait, be alert and collected in the bridle.
 3. Extended Rack: The extended rack shall be a comfortable easy going four beat gait in which speed is not a factor, but easily distinguished from the slow rack. The horse will be collected in the bridle at all times.

Horses shall enter the ring at a slow rack prior to the initial judging of the class. After all entries have entered the ring, they will be judged in the three (3) gaits beginning with the brisk walk.

Horses shall stand quietly and back readily.

This class will follow all pleasure division requirements for shoeing and biting.

This class is open to amateur and youth exhibitors and shall be shown in English tack and attire.

Section 11.8 PARK PLEASURE DIVISION

- (a) A Park Pleasure horse shall be dependable and pleasurable to ride and should exemplify the ultimate Racking Horse as a personal mount. Emphasis on judging should be placed on manners, quality, and compatibility of horse and rider. In the execution of its three gaits, the horse should exhibit smoothness of ride, a high head, and may exhibit more animation than a Trail Pleasure mount, however, less than an Open Flat Shod horse. The horse will be shown with a light rein. Bumping and pumping of the reins will be penalized. This horse must back readily.
- (b) Three gaits will be called:
 - (1) Park Pleasure Walk,
 - (2) Park Pleasure Slow Rack and
 - (3) Park Pleasure Fast Rack.

The Park Pleasure walk will be a snappy four-beat walk without the speed or animation of the Slow Rack. The Park pleasure

Slow Rack will be a comfortable, easy-going rack in which speed is not a factor. Front lift should not exceed the height of level. The Park Pleasure Fast Rack is a distinct extension of the Slow Rack. Form shall not be compromised for the sake of speed. Any indication of strain on horse or rider in any gait will be penalized.

- (c) For shoeing requirements, refer to Section 8.7A.

Section 11.9 SHOW PLEASURE DIVISION

- (a) A Show Pleasure horse shall be dependable and pleasurable to ride. In the execution of its three gaits, the Show Pleasure horse should exhibit smoothness of ride required of the true natural Racking Horse, exhibiting a higher head than the Trail Pleasure horse without the look of an Open Show horse and exhibit more animation than the Trail Pleasure mount. Front lift must not exceed the height of level and is generally accepted as having lift somewhat below level and less than the Style Pleasure mount. A Show Pleasure horse shall be shown with a light rein, but not loose; both horse and rider must be relaxed and comfortable. Any indication of strain on the part of the horse or rider will be penalized.
- (b) Show Pleasure horse will be shown at three gaits:
 - (1) Show Pleasure Walk, (2) Show Pleasure Rack and (3) Show Pleasure Fast Rack. The Show Pleasure Walk will be a snappy type walk, but will not have the speed or animation of a Slow Rack. The Show Pleasure Slow Rack will be executed at a distinct gait from the Show Pleasure Walk, and will again lack the animation of a Slow Rack when compared to the Open Division of Racking. The Show Pleasure Fast Rack will be a comfortable easy going rack in which speed is not a factor but should be easily identifiable from the other two gaits required of this division.
- (c) The Show Pleasure horse shall enter the ring at a Show Pleasure Walk prior to initial judging of the class. Three gaits will be called for, beginning with the Show Pleasure Walk, after all entries have entered the ring prepared for being judged.
- (d) The Show Pleasure Division will be an open shod class with

pads. Shoeing requirements regarding length of hoof, toe-to-heel, are as required by USDA Rules and Regulations.

Section 11.10 STYLE PLEASURE DIVISION

- (a) The Style Pleasure horse shall be dependable and pleasurable to ride, shown with a light rein, but not loose, shall be more reasonably mounted in the bridle than the Show Pleasure horse displaying style over animation. The front lift must not exceed the height of level yet is generally accepted to have more lift than the Show Pleasure mount with a more striding back end. Both horse and rider must be relaxed and comfortable, exhibiting a smooth ride. Any indication of strain on the part of the horse or rider will be penalized.
- (b) A Style Pleasure horse will be shown at two gaits: (1) Style Pleasure Walk and (2) Style Pleasure Rack. The Style Pleasure Walk will be a true stylish walk, but will not have the speed or animation of an Open Show Walk. The Style Pleasure Rack will be a comfortable easy going rack in which speed is not a factor in judging.
- (c) The Style Pleasure horse shall enter the ring at a Style Pleasure Walk, prior to initial judging of the class. Two gaits will be called for, beginning with the Style Pleasure Walk, after all entries have entered the ring prepared for being judged.
- (d) The Style Pleasure division will be an open shod class with pads. Shoeing requirements regarding length of hoof, toe-to-heel, are as required by USDA Rules and Regulations.

Section 11.11 MODEL HALTER

Section 11.12 LEAD LINE DIVISION

The Lead Line Division became recognized by the Racking Horse Breeders' Association of America to provide its youngest exhibitors an opportunity to experience and enjoy show ring competition.

The Division is open to Juveniles aged six years and under and is

shown in two classifications: (1) Lead Line Riders on Horses and (2) Lead Line Riders on Ponies, both of which will be shown at a walk both ways of the ring. Each entry is led by a responsible person at the lead and there may also be an assistant to walk at the side of the rider to avoid mishaps. Safety of the young rider is of paramount importance.

Attention may be given to coordination of attire of rider, leader and assistant; good behavior of horse or pony is a point of emphasis in addition to that of the rider.

Although Lead Line classes are judged, it is to be remembered that this is a fun class to introduce our youngest Juvenile riders to the show ring. Lead Line ponies are not required to be registered Racking Horses.

Section 11.13 FLAT SHOD DIVISION

- (a) Due to the versatility of the Racking Horse to adapt to any conditions, a division of Flat Shod horses, which shall be defined as being hoof-to-shoe with no pad of any type, whether for corrective purposes or otherwise, is recognized by the Racking Horse Breeders' Association of America. This division is eligible to compete in any class desired by the owner that is designated "Open Shod" with the exception of any Pleasure Division.
- (b) The Flat Shod horse shall enter the ring at a Show Walk, prior to initial judging of the class. According to the class (Flat Shod Style, Flat Shod Open), either two or three gaits will be called for, beginning with the Show Walk, after all entries have entered the ring prepared for being judged.
- (c) For shoeing requirements refer to Section 8. 7A.

Section 11.14 OPEN SHOW DIVISION

- (a) Emphasis is not placed on this division, although the interest of the Racking public has dictated that this be the model division of the Racking Horse in America. This division shall be open shod, and shall be required to execute the three (3) gaits of the Racking Horse (Exceptions: Style, Two-Year-Old, Two-and Three- Year-Old combination, Fine Harness,

Juvenile 12 Years and Under). The desirable qualities of the Racking Horse, in all three (3) gaits, shall be required and the headset shall be collected and well mounted in the bridle. This division of Racking shall typify the true show horse as specified by the Racking Horse Breeders' Association of America. All classes shall be open to the Racking public, except where age limitations are set upon exhibitors.

- (b) The Open Show horse shall enter the ring at a Show Walk, prior to initial judging of the class. According to the class (note exceptions in paragraph above), either two (2) or three (3) gaits will be called for, beginning with the Show Walk, after all entries have entered the ring prepared for being judged.

Section 11.15 SPECIALTY ACTION DIVISION

Emphasis is not placed on this division; although the interest of the Racking Horse Membership has dictated the RHBA have a division using an action device. This division will be shown in pads and flat shod and meet the requirement of the HPA shoeing rules and regulations. Action devices that are permitted by HPA to be used in this division. This division will consist of TWO-YEAR-OLDS, THREE-YEAR-OLDS, and FOUR-YEAR-OLDS AND AGED HORSES. The classes can be divided between Genders, Open Amateur and Youth and are required to execute the three (3) gaits of the Racking Horse. (Exceptions: Youth 12 and under, Two-Year-Old and any combination with a Two-Year-Old horse in said class. These will perform two (2) gaits, the show walk and the slow rack). Championship classes for this division will be limited to this division only and will be unable to show in any other Championship class.

- (a) Tack, dress and showmanship to be the same as in section 11.12, Open Division.
- (b) Judging Specifications to be the same as specified in Article XII Section 12.1 (1) thru (11).
- (c) Any horse with a punching gait or excessive head nod will be excused.
- (d) There will be no pleasure classes in this division.

The Specialty Action Horse shall enter the ring at a show walk, prior to the initial judging of the class. (2/19/05)

Section 11.16 RACKING HORSE TO BIKE

(a) The cart to be used is to be an appropriate two-wheel cart.

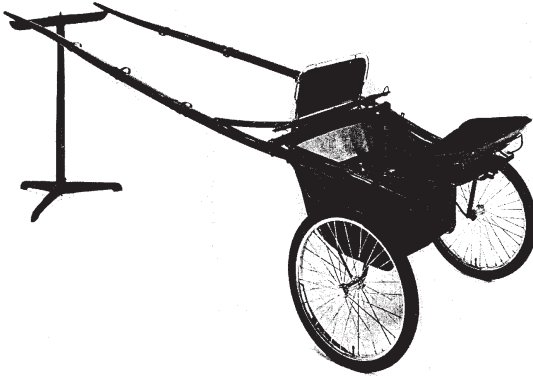

(b) Approved harness shown below.

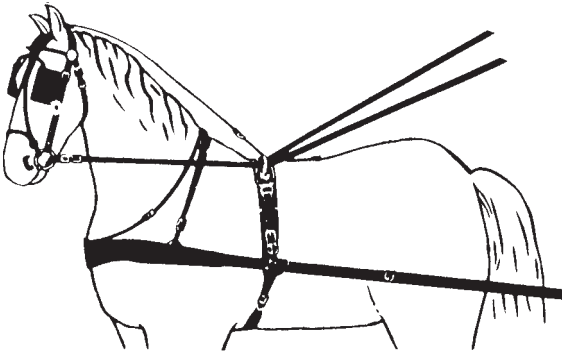

(c) A horse shown in this division shall exhibit all the desirable qualities of a true show horse in the performance of his gaits. The headset shall be collected and well mounted. Entries shall be required to execute three (3) gaits, the Show Walk, Slow Rack and the Fast Rack, with excessive speed being

penalized. Shoeing for this division shall be open. Horses shall be shown in an appropriate cart and light harness with blind bridle, overcheck and a snaffle bit. Drivers shall be attired in the traditional English riding habit.

- (d) The Racking Horse to Bike shall enter the ring at a Show Walk and turn to the left so that they shall be shown first in a clockwise direction. Three (3) gaits will be called for, beginning with the Show Walk, after all entries have entered the ring prepared for being judged.
- (e) Racking Horse to Bike does not qualify the horse for any "under saddle" Championship.

Section 11.17 RACKING HORSE TO FINE HARNESS

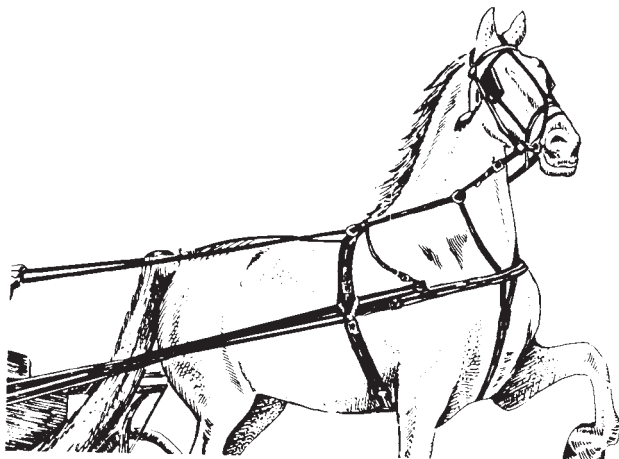

- (a) The Fine Harness Racking Horse should possess all of the elegance and refinement of the ideal Racking Horse, and its energy should be directed toward motion, animation and form rather than speed. It is the epitome of the show horse.

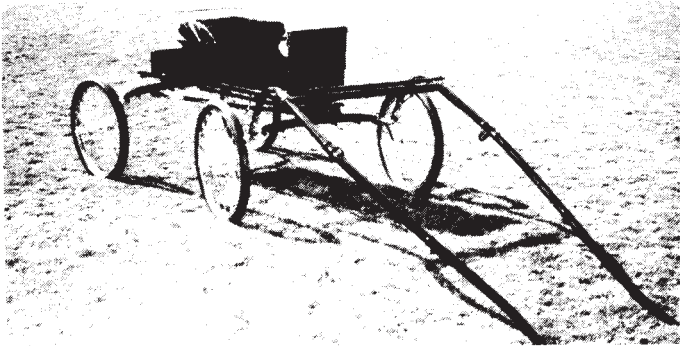

- (b) The Fine Harness Racking Horse is shown to an appropriate vehicle, driving a small buggy with four wire wheels. Light harness, driving bit, blinkers and overcheck are required. Curb bits are prohibited, unless they are driving bits, such as a Kimberwick bit.
- (c) Fine Harness Racking Horses are to enter the ring to the right at a Show Walk. Qualifying gaits are Show Walk and Style Rack. One attendant per entry will be permitted to stand quietly inside the gate but must take no action that will affect the performance of any horse.
- (d) On the line-up, entries may be unchecked, but they are to stand quietly. An attendant may park the entry, but thereafter remain at least two paces from the entry's head. Attendant shall be appropriately dressed.
- (e) Proper attire for lady exhibitors may include dresses, pants suits or riding habits. Gentleman exhibitors shall wear suits, sports coats or riding habits and hats.
- (f) The Fine Harness class does not qualify a horse for any "under saddle" championship.
- (g) Shoeing for this division shall be open.

Section 11.18 SPOTTED RACKING HORSES Spotted Racking Horse gaits, tack and attire shall be according to class and/or division in which exhibited.

Section 11B.1 PLEASURE RACKING HORSE

VERSATILITY PROGRAM: The purpose of this Program is to promote the utilization of the Racking Horse in all aspects of the pleasure horse industry and to establish a Register of Merit system through which points accumulated and outstanding horses honored by awards.

Section 11B.2 BITTING IN PLEASURE DIVISIONS:

Severe bits must be penalized in the final judging. Shanks over nine and 1/2 inches are prohibited. Gag bits without shanks are not allowed. Shanks are measured from the top of the metal to the very bottom of the metal, including the rings. Cross chain cavessons are prohibited.

Section 11B.3 PLEASURE DIVISIONS CLASSES:

Trail Pleasure	Trail Obstacle
Trail Pleasure Lite Shod	Endurance or Competitive
Country Pleasure	Rides and Judges Trail
Country Pleasure Lite Shod	Rides
Pleasure Driving	Promotion
Western Pleasure	Cloverleaf Barrels
Western Pleasure Lite Shod	Fifty Yard Dash
Pleasure Racking	Jumping
Model (Halter)	Music Free Style
Showmanship at Halter	Pole Bending
Youth (17 & Under)	Team Penning
Water Glass	

The Versatility Program has been arranged to encourage the participation of the flat shod Pleasure Racking Horse and exhibitor in a maximum number of events. The Program is open to Juveniles and Adults in accordance with the official Rule Book of the Racking Horse Breeders' Association of America.

Section 11B.4 ELIGIBILITY:

Versatility Program horses must be nominated each year. To nominate a horse, a completed form must be returned to the RHBAA office that lists the name of the horse and its owner, the rider and the rider's address and phone number. Membership in the Racking

Horse Breeders' Association of America is required for both owner and rider. Cumulative points go to horse, not rider. If ownership changes and if both parties were members of the Racking Horse Breeders' Association of America before selling, points shall follow the horse. You may count points won in an all-breed show. Judges must be licensed with a nationally or internationally licensed program recognized by the RHBAA. Points are tabulated from the date of nomination filed at the RHBAA office until the end of the calendar year. Rider must have a current Exhibitor Status Card issued by the RHBAA.

Section 11B.5 CLASS DESCRIPTIONS

- (A) Trail Pleasure: See Section 11.4
- (B) Trail Pleasure Lite Shod: See Section 11.4(f)
- (C) Country Pleasure: See Section 11.5
- (D) Country Pleasure Lite Shod: See Section 11.5(g)
- (E) Pleasure Driving

Horse is to enter to the right (counter-clockwise) and work both ways of the ring at a Pleasure Walk and Pleasure Rack. Reverse will be at the direction of the ringmaster. The horse will be asked to line up, stand quietly, and back readily. The horse should be judged by the same general qualities as the Trail horse: 70% on manners, performance, way of going and condition; 20% on suitability of vehicle and harness; 5% on conformation; 5% on neatness of driver. Separate overcheck bit is optional; however, an approved driving bit is required.

Appointments and Rules:

- (1) Any two- or four-wheel single-seat vehicle of suitable safety and appearance. Breeching is not used with wire wheels and is recommended with wooden wheel vehicle. Driver only in the vehicle unless the driver is a juvenile, who may have one attendant (appropriately dressed).
- (2) Harness should be black leather with square leather blinkers, snaffle bridle with side check or overcheck, and running martingale.

- (3) An appropriate whip may be used.
- (4) Lady drivers should wear an informal dress, skirt and blouse, or conservative riding suit. Men should wear a riding suit, a business suit or a sport jacket with tie. Gloves are recommended. Hats and aprons are optional.
- (5) Unruly horses shall be immediately dismissed. Unsafe equipment or vehicle also warrants dismissal.
- (6) A neatly attired header may enter ring and assist with parking on the line-up or when needed for an unsafe condition.

(F) Western Pleasure: See Section 11.6

(G) Western Pleasure Lite Shod: See Section 11.6(g)

(H) Pleasure Racking Flat Shod: See Section 11.7

(I) Model: Model Classes are to be Shown in Bridle Only.

Model classes are to be shown in bridle only. Horses shall be led into the ring and parked for judging. Entry is to be judged mainly on conformation and conditioning, and any transmittable weaknesses or unsoundness must be severely penalized. A whip in length up to three feet may be used. Horses must be well-mannered or be excused from the ring. Tack and exhibitor's apparel shall be either English or Western, but not a combination of both.

(J) Showmanship At Halter By Youths 17 Years Old and Under

Designed to furnish the youth exhibitor an opportunity to demonstrate his or her ability to fit and show a conformation horse. Judging shall be based on the exhibitor ability, and no consideration shall be given to the horse with the exception of the grooming and the fitting. Horse must be two years old or older. Attire for this class may be either English or Western, but not a combination of both, and must be clean and neat.

A. How Judged:

1. Appearance of Exhibitor (10 points)

- (a) Suitable English or Western Attire, but not a combination.
- (b) Attire and person and must be neat and clean.

2. Appearance of Horse (40 Points)
 - (a) Condition (15 Points).
 - (b) Grooming (15 Points): Hair coat clean and well groomed with mane and tail clean and free of tangles.
 - (c) Trimming (5 Points): Inside of ears trimmed, bridle path trimmed, long hair on jaw trimmed, legs and pastern trimmed.
 - (d) Tack (5 Points): Halter and lead shank should be neat, clean and in good repair.
3. Showing Horse in Ring (50 Points)
 - (a) Leading (15 Points)
 1. Enter the ring in the direction indicated by the ring steward and walk until the Judge requests that the horse line up for inspection. Walk on the horse's left side, holding the lead shank in the right hand, near the halter. The remaining portion of the lead shank shall be held lightly and safely in the left hand. Horse should lead readily at a walk.
 2. After the Judge has lined up the class, the exhibitor should be sure that the Judge gets a clear, unobstructed view of the horse.
 3. If the exhibitor is asked to back his or her horse, the exhibitor should back the horse smoothly, one step at a time, as straight as possible for one body length. Do not change hands on the lead shank.
 - (b) Posing Horse (15 Points):
 1. When posing the horse, the exhibitor should stand at the front of the horse facing the horse with his or her toes pointed toward the horse's eye or neck. The exhibitor should not stand directly in front of the horse but should always stand in a position where he or she can keep an eye on the Judge. When the Judge

looks at either hindquarter of the horse, the exhibitor stays on the same side as the judge with his or her toes pointed toward the horse's eye or neck. When the Judge looks at either front quarter, the exhibitor crosses to the opposite side of the horse. When posing the horse, do most of the showing with the lead shank. The exhibitor should not touch the horse with his or her hand.

2. Never change hands on the lead shank or kick the horse's leg into position.
3. Never crowd the exhibitor next to you when in a side-by-side position.
4. Never crowd the exhibitor in front when lined up head-to-tail.
5. Always leave a horse's length between you and the next horse.

(c) Poise, Alertness and Merits (20 Points)

Keep alert and be aware of the position of the Judge at all times. Do not be distracted by persons or things outside the ring.

(K) Water Glass

The purpose of this class is to show the smooth gait of a Racking Horse. Each entrant is given a full glass of water to hold in either hand. When the gate is opened, all entries come in at a Pleasure Walk. All entries will execute a Pleasure Walk and Slow Rack both ways of the ring. The entrant with the most water left in his or her glass wins. In case of a tie, a Fast Rack will be called for to break the tie.

(L) Trail Obstacle

(Course to be Posted Prior to Class)

(a) Mandatory Obstacles

(Choose any three; all can be used)

1. Opening, passing through and closing gate.
2. Ride over wood bridge (may be

plywood).

3. Cavaletti (entrant over at least four logs spaced on ground).
4. Ground-tie horse, walk full circle around horse.

(b) Optional Obstacles

1. Back Through: Place poles in L-shape 36 inches apart; bales on edge are suitable, parallel poles could be used.
2. Jump 18 to 24 Inches: Horse may be ridden or led over. Straw bales on edge make a good jump.
3. Mail Box: Rider may ground-tie horse while he or she goes to box or rider may approach box while mounted.
4. Water Hazard: May also use panel of canvas, plastic, etc.
5. Raincoat On Post: Rider must put raincoat on, remove it and hang it up.
6. Walk Through Serpentine: Six-foot lath upright, set in cement-filled cans, spaced 30 inches apart (also can be used for Back Through).
7. Booger On a Barrel: Animal hide draped over barrel or caged live animal on barrel. Entrant must pass within three (3) feet.

(M) Endurance or Competitive Rides and Judged Trail Rides

In competitive or endurance rides, points are awarded as follows: First finishing Racking Horse, 3 points; Second finishing Racking Horse, 2 points; Third finishing Racking Horse or any Racking Horse completing the course, 1 point.

1. Judged Trail Rides: 1 1/2 points for Racking Horse receiving First place, 1 point to Second place and 1/2 point for all Racking Horses completing the ride.
2. Endurance Rides: Must be an organized

ride under the supervision of a veterinarian experienced with endurance horses. The ride must be a minimum of 50 miles in length per day, with a maximum of 200 miles in 3 days. The winner is the horse and rider completing the ride first. Horses must be at least five years old. There is no minimum time limit.

3. Competitive Rides: Judging is based on each entrant beginning with a 100-point score. Manners, 15%; Smoothness: 5%; Soundness: 40%; Condition 40%. Although judging mainly concentrates on the horse, the rider is also judged on the care and handling of his or her mount. Only mounted forward movement can be counted. Horses must be five years old or older. Judging criteria are: time, distance and stress, not speed. The horses are well worked over the same trail in the same length of time. This is not a race; however, time and pacing the ride are important. The winner will be the entrant that rode at the most consistent pace for the entire ride.
4. Judged Pleasure Rides: Must be no more than 25 miles a day. Entrants will be judged on the ability to negotiate normal trail conditions and obstacles in a stress-free, trail-wise manner. Must ride quietly with other mounts. Must back readily. Horse must execute a smooth, easy gait. Entrants are responsible for manners of themselves and mounts. No tailgating, racing or showboating. Ask to pass riders on the left.

(N) Promotion

One point will be given a horse that participates in a live exhibition at an event in which the Racking Horse is officially recognized as a breed. Subject to RHBAA approval. Points in Promotion cannot be above CHAMPION AWARD.

(O) Basic Reining (Two Patterns Only)

To rein the horse is not only to guide him, but also to control his every movement. The best-reined horse should be willingly guided or controlled with little or no apparent resistance and dictated to completely. Any movement on his own must be considered a lack of control. All deviations from the exact written pattern must be considered a lack of or temporary loss of control. Therefore, a fault must be marked against the pair according to the severity of the deviation.

After deducting all faults set within each pattern (against execution of the pattern and the horse's overall performance), credit should be given for smoothness, finesse, attitude, quickness and authority of performing various maneuvers. The horse and rider team must demonstrate controlled speed, which raises the difficulty level and makes him more exciting and pleasing to watch for an audience.

(Both patterns are to be worked as stated, not as drawn.)

Markers will be placed on the wall or fence of the arena as follows:

- a. At the center of the arena.
- b. At least 50 feet from each end wall.

Where designated in the pattern for stops to be beyond a marker, the horse should begin his stop after he passes the specified marker. Each pattern is drawn so that the bottom of the page represents the end of the arena entered by contestants and must be run as such. In the event that an arena has only one gate and it is in the exact middle of one side, that side shall represent the right side of the page the pattern is drawn on. All horses shall be judged immediately

upon entering the arena and judging will cease after the last maneuver. Any fault incurred prior to the commencement of a pattern will be scored accordingly.

Pattern #1

1. Proceed fast to the far end of the arena past the end marker and do a left rollback with no hesitation.
2. Proceed fast to the opposite end of the arena past the end marker and do a right rollback with no hesitation.
3. Proceed fast past the center marker and do a sliding stop. Back up to center of the arena or at least ten feet. Hesitate.
4. Complete four spins to the right.
5. Complete four and one-fourth (4 1/4) spins to the left so that the horse is facing left wall or fence. Hesitate.
6. Proceed fast, complete three (3) circles to the left: the first circle large and fast; the second circle small and at a Slow Rack; the third circle large and at a Fast Rack. Shift weight at center arena.
7. Complete three (3) circles to the right: the first circle large and fast; the second circle small and slow; the third circle large and fast.
8. Begin a large circle fast to the left but do not close this circle. Proceed fast straight up the right side of the arena past the center marker and do a sliding stop at least twenty (20) feet from wall or fence. Hesitate, to demonstrate the completion of the pattern.
9. Rider must drop bridle to the designated Judge.

(See illustrations for Reining diagram.)

Basic Reining Pattern #1:

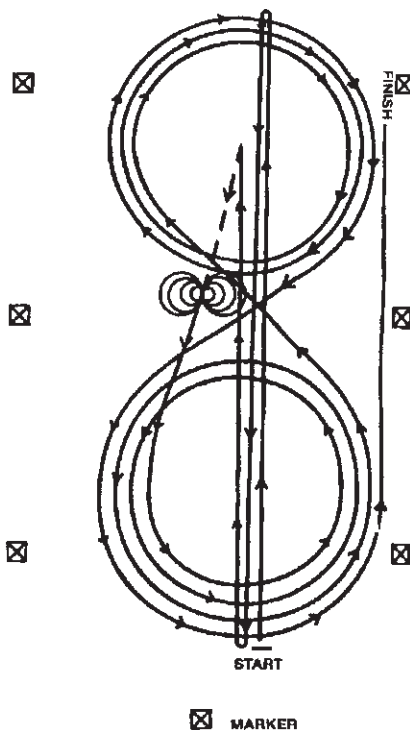

Pattern #2

1. Beginning and staying at least twenty (20) feet from the walls or fence, proceed fast straight up to the left side of the arena. Circle the top end of the arena, proceed fast straight down the opposite, or right, side of the arena past the center marker and do a left rollback with no hesitation.
2. Continue straight up the right side of the arena, staying at least twenty (20)

feet from the walls or fence. Circle back around the top of the arena, proceed fast straight down the left side of the arena past the center marker and do a right rollback with no hesitation.

3. Continue up the left side of the arena to the center marker. At the center marker, the horse should begin and proceed slowly. Guide the horse to the center of the arena and complete three (3) circles to the right: the first two circles large and fast, the third circle small and slow. Come back to center of the arena.
4. Complete three (3) circles to the left: the first two (2) circles large and fast, the third circle small and slow. Come back to center of the arena.
5. Begin a large fast circle to the right but do not close this circle. Continue up the left side of the arena staying at least twenty (20) feet from the walls or fence, circle the top of the arena, proceed fast straight down the opposite or right side of the arena past the center marker and do a sliding stop. Back up at least ten (10 feet).
 1. Complete four spins to the right.
 2. Complete four spins to the left.
 3. Hesitate, to demonstrate completion of the pattern.
 4. Rider must drop bridle to designated Judge. (See illustrations for Reining diagram.)

Basic Reining Pattern #2:

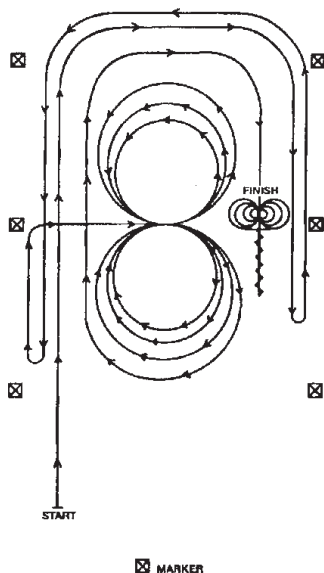

(P) Cloverleaf Barrels

Western equipment must be used. When measuring and preparing the arena for the Cloverleaf Barrels, remember to leave ample room for the horses to complete their turns and to stop at the finish. A clearly visible starting line shall be provided, either through the use of marked line on the ground, or between two cones placed opposite each other. Barrel Racing is a timed event. An electric timer or at least two (2) stopwatches shall be used.

Timing shall begin as soon as the horse's nose reaches the starting line and will be stopped when the horse's nose passes over the finish line.

At a signal from the Starter, the contestant will proceed to barrel #1, pass to the left of it, and complete an approximate 360-degree turn around it; then go to barrel #2, pass to the

right of it, and complete a slightly more than 360-degree turn around it. Finally, go to barrel #3, pass to the right of it, and do another approximate 360-degree turn around it and then proceed to the finish line. Horses are not to run out of the arena gate. The barrel course also may go to the left if the rider prefers. Knocking over barrels will cause a five-second penalty per barrel. A contestant may touch the barrel with his or her hand. Any contestant who breaks the pattern or fails to follow the course shall be disqualified. If the rider loses his or her hat, he or she will receive a five-second penalty. (See illustrations or Cloverleaf diagram.)

Barrel Racing Diagram
Cloverleaf Barrels Pattern #1

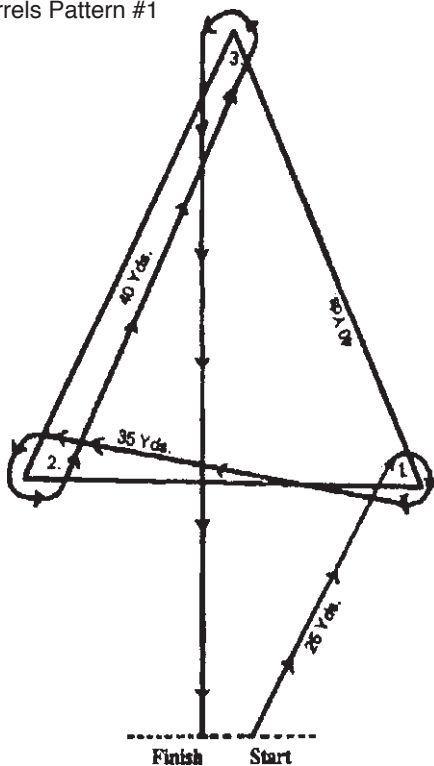

(Q) Fifty-Yard Dash

Western equipment must be used. Fifty-Yard Dash is a timed event.

When measuring the arena for the Fifty-Yard dash, remember to leave ample room for the horses to complete their turns and come to a stop at the finish. Measure the fifty (50) yards from the starting line. The horse and rider team proceeds from the starting line to the barrel, executes a turn around the far side of the barrel and proceeds to the finish line. A five-second penalty is assigned if a barrel is knocked over or if the rider loses his or her hat. Proper attire is required.

(R) Jumping (Not to Exceed 2.5 Feet)

Fences should simulate obstacles found in the hunting field: poles and rails, brush, wall, gates and coops, etc., and have the appearance of being solid. Jumper fences such as bull's eyes and stripes and spreads of over four feet are prohibited. The maximum jump is not to exceed 2.5 feet in height. The horse and rider team should perform a full circle before starting the course and sets the speed for the duration of the course. A circle may be made at the finish. Faults are knockdowns, extra circle and refusals. Elimination results from third refusals, being off course, fall of horse and/or rider, jumping out of order, jumping before jump or jumps are reset. Protective helmet, English equipment, snaffle, kimberwick or Pelham bit are permitted. Martingales, non-weighted rubber bell boots, polo wraps, and splint boots are permitted. (See illustrations for jumping diagram.)

Over Fences Pattern #1

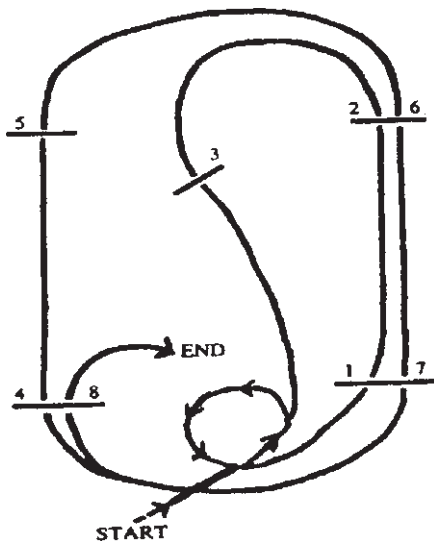

Jumping Diagram
Over Fences Pattern #2

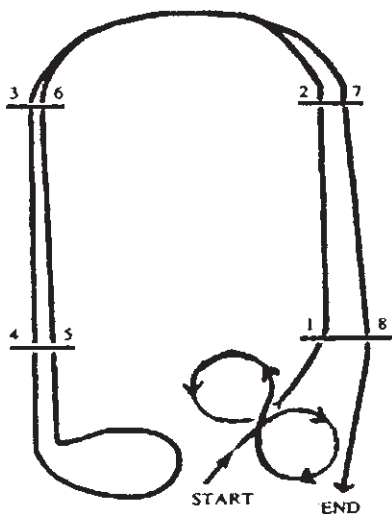

(S) Freestyle

The Music Freestyle class is a music routine performed within four (4) minutes by the horse and rider. The team of the horse and rider will be scored in the following five categories:

1. Appropriate theme to the music, such as costume, skit, etc.
2. Movements in time with tempo of the music.
3. Six "movements" must be exhibited: Side left, side right, 360-degree circle on the front, spins, small circles, halt, back, serpentine, fast rack, slow rack, walk, sliding stop, roll back, one unusual or different movement not listed.
4. Time not to exceed four (4) minutes.
5. Three distinct gaits must be performed: Slow Rack, Fast Rack, and Walk. There must be a distinct difference in the gaits.

(T) Pole Bending

Western equipment must be used. Pole Bending is a timed event.

The pole bending pattern is to be completed around six poles. Each pole is to be twenty-one (21) feet apart and the first pole is to be twenty-one (21) feet from the starting line. Poles shall be set on top of the ground, six inches in height and with no base larger than fourteen (14) inches in diameter. A horse and rider may start to the right or to the left of the first pole and then complete the remainder of the pattern accordingly.

Knocking over a pole, touching the pole with the rider's hand shall cause a five-second penalty. Failure to follow the course shall cause disqualification. If the rider loses his or her hat, a five-second penalty is assigned. (See illustrations for Pole Bending diagram.)

Pole Bending Pattern Diagram

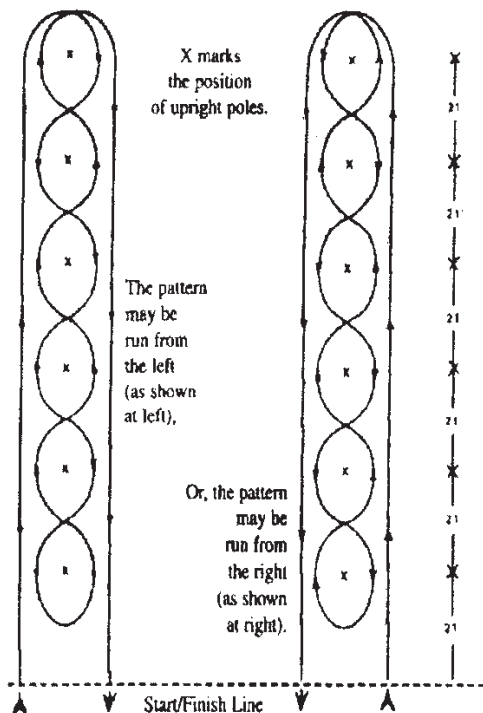

(U) Team Penning

Team Penning is a three-person, three-horse event. The RHBAA Member need not be partnered with other RHBAA Members to receive Versatility Points. The three-person team must wait until the timer indicates the cattle are ready to be penned before beginning. Beginning before this time will constitute a disqualification. The team is allowed two (2) minutes to pen three (3) designated cattle. Cattle are not to be roughed up or run down.

The cattle must be penned inside the pen and only one horse and rider may step over the finish line. A raised hand indicates the penning is completed. If too many cattle cross the foul line, the team penners will be disqualified. The horse may not step into the pen. The back quarters of the horse may not cross the finish line.

Section 11B.6: RACKING HORSE BREEDERS' ASSOCIATION OF AMERICA NATIONAL PLEASURE VERSATILITY AWARDS

Versatility Awards will be given to adults and juveniles in each division. Juvenile Participation Certificates will be awarded regardless of the number of points earned at year's end.

- (a) High Point Class Award
Must be greater than 10 points yearly. Awarded to horse that earns the most points during show year.
- (b) Certificate of Merit
Awarded when a rider and his or her horse have earned 10 points in two (2) or more events within one year.
- (c) Versatility Champion
Forty-five (45) or more points to earn plaque.
 - (a) Points must be won in five different shows under five different Judges.
 - (b) Minimum number of 5 points in Model or Halter classes.
 - (c) Minimum number 15 points earned in at least three (3) performance classes.

Prerequisite to the SUPERIOR CHAMPION is the CHAMPION status.

- (d) Superior Versatility Champion
Seventy-five (75) points or more to earn trophy. Awarded to the Racking Horse that has won:
 1. Ten (10) or more points in Model or Halter classes.
 2. Forty-five (45) or more points in Versatility performance classes.
 3. Fifteen (15) of these 45 points must be won in three or more of the following divisions:
 - (A) English Trail Pleasure

- (B) Pleasure Racking
- (C) Western Pleasure
- (D) Country Pleasure

4. At least 10 points won in two (2) or more of the following divisions:

- | | |
|---------------------------------|---------------------|
| (A) Trail Obstacle | (G) Jumping |
| (B) Pleasure Driving | (H) Music Freestyle |
| (C) Endurance/Competitive Rides | (I) Pole Bending |
| (D) Basic Reining | (J) Team Penning |
| (E) Cloverleaf Barrels | (K) Water Glass |
| (F) Fifty-Yard Dash | |

5. Twenty (20) or more points must have been earned at an RHBA affiliated State Racking Horse Show. A horse may earn up to but not more than 5 points (1 point per class) for entering and exhibiting in a Pleasure Division offered at the Spring or Fall Celebration, regardless of placement.

(e) Points

Points shall be awarded as follows: Basis of placement and the number of entries in a given class to a maximum of 5 points in any one class.

Second place winners shall receive 1 point for each three horses placed over to a total of 4 points in anyone class. Third place winners shall receive 1 point for each three horses placed over to a maximum of 3 points. Fourth place winners shall receive 1 point for each three horses placed over to a maximum of 2 points. Fifth place winners will receive 1 point for each three horses placed over to a maximum of 1 point. No points will be awarded below fifth place. If fewer than three horses in class, then First place will receive "1" Promotion point.

(f) Versatility Point Books

Point Books will be issued each year. The points continue from year-to-year if eligibility requirements are met. Versatility Point Books must be postmarked by December 1 for points to count. Points are awarded on the basis of placement and the number of horses actually shown. An

entry sheet or class sheet for each show must be included with your Point Book. Circle number of classes won.

Section 11B.7 GENERAL REQUIREMENTS

1. No pads. Youths 17 years of age and younger are eligible to show mares or geldings only. All horses must be two years of age or older.
2. Juveniles whose parents are not Members of the Racking Horse Breeders' Association of America may become members of the Versatility Pleasure Program upon payment of an initial Nomination fee of \$10.00.
3. An annual fee of \$4.00 will continue the qualification each year.
4. For shoeing requirements, refer to Section 8.7 A.
5. Equipment approved for either English or Western tack is approved for non-performance classes but not a combination thereof.
6. Exhibitors' Apparel:
 - (a) Western apparel to include a long sleeve shirt, hat and tie. Chaps are optional.
 - (b) English apparel to include an English Riding Habit. All riding attire shall be neat and properly fitted. A snap-brim hat is required for gentlemen. Hats for ladies are optional. Hair must not obstruct the back number.

Section 11B.8 BASIC OBSTACLE COURSES

Pattern #1

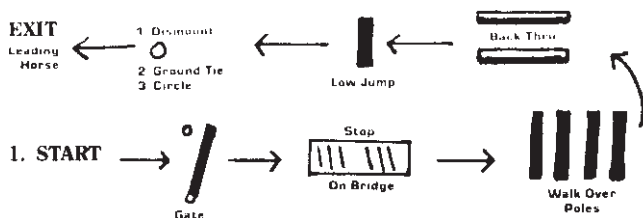

Pattern # 2

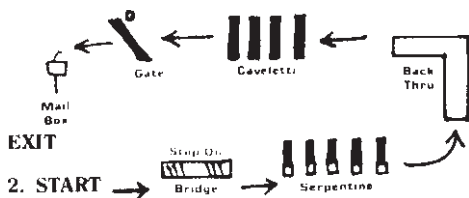

Section 11 C.1 “RACK ACROSS AMERICA” TRAIL HOURS PROGRAM:

(a) Purpose

In 1998, the Racking Horse Breeders’ Association of America Pleasure Association established the “Rack Across America” Program for trail riders. This program is independent of any Versatility point-accruing event. The RHBAA Pleasure Association developed this program for trail riders in an effort to recognize the many trail horses of the RHBAA.

(b) Eligibility

A horse may be entered in the Versatility Program as well as the “Rack Across America” Program; however, the horse may not collect Versatility Points, whether promotion or from events, and also log “Rack Across America” trail hours for the same ride. It is the “Rack Across America” trail-hour program that is to be logged in a Trail Hour Log Book. A trail rider may obtain these by:

1. Being a current Member of the RHBAA.
2. Being a current member of the RHBAA Pleasure Association.
3. Having a RHBAA-registered trail horse.
4. The horse’s owner must also be a member of both the RHBAA and the RHBAA Pleasure Association.
5. Youths may either use their parent(s)’ RHBAA membership number or may join the RHBAA of their own accord.
6. Youth membership in the RHBAA Pleasure Association follows the same stipulations as #5 above.

(c) Criteria

1. Trail Hour Log Books are due to be sent to the “Rack Across America” Program Coordinator and must be postmarked by December 31 of each year. The hours go with the horse in the event that the horse should be sold. The current owner/rider must be a Racking Horse Breeders’ Association of America Member. Hours logged must be forward-moving hours. For example, time spent visiting, sitting, picnicking, etc., would not count. Trail rides that would NOT count would be any RHBAA Versatility Program activity. For example, ride time at a recognized show, competitive trail, endurance, judged pleasure, judged trail obstacle.
2. All hours are to be logged and must be rounded to the nearest full hour. Upon completion of 50, 100, 250, 500, and 1,000 hours, the rider should send the “Rack Across America” Trail Hour Log Book to the designated RHBAA “Rack Across America” Coordinator. Awards will be given at the RHBAA annual awards ceremony (RHBAA annual Winter Meetings). If the rider cannot attend the awards ceremony, the awards will be mailed out after the ceremony.
3. The “Rack Across America” Program promotes safe trail riding by recommending that riders wear protective gear and travel with one or more companions. In order to log hours, one other person who witnessed the trail ride needs to initial the Log Book to verify actual hours earned.

(d) Incentives/Awards

1. 50 Hours = RHBAA “Rack Across America” Patch
2. 100 Hours = First Bar
3. 250 Hours = Second Bar
4. 500 Hours = Third Bar
5. 1000 Hours = Final Championship Bar and Championship Award

ARTICLE XII

CLASS SPECIFICATION, JUDGING PERCENTAGE, SANCTIONED CLASSES AND RETIREMENT CEREMONIES

Section 12.1 CLASS SPECIFICATION AND JUDGING

PERCENTAGES: The following classes may be divided according to the sex of the horse (stallion, mare or gelding). Classes may be divided according to height, 15.2 hands and under or over 15.2 hands:

1. **Two-Year-Old Racking Horses:** To be judged 45% Show Walk, 45% Slow Rack, 10% Conformation. A Two-Year-Old class shall be worked no longer than a maximum of 10 minutes without a five-minute rest period.
2. **Combination Two- Three- and Four-Year-Old and Junior Racking Horses:** In the event of a combination Two-Three-Four- Year Old and Junior Racking Horse class, the judging shall be made on the basis of a Show Walk and Slow Rack with percentages as follows: 45% Show Walk, 45% Slow Rack, 10% Conformation. A Two-Three-Four-Year-Old and Junior combination class shall be worked no longer than a maximum of 10 minutes without a five-minute rest period.
3. **Three-Year-Old Racking Horses:** To be judged 30% Show Walk, 30% Slow Rack, 30% Fast Rack, 10% Conformation.
4. **Four-Year-Old Racking Horses:** To be judged 30% Show Walk, 30% Slow Rack, 30% Fast Rack, 10% Conformation.
5. **Aged Racking Horses:** To be judged 30% Show Walk, 30% Slow Rack, 30% Fast Rack, 10% Conformation.
6. **Ladies Racking Horses:** To be judged 30% Show Walk, 30% Slow Rack, 30% Fast Rack, 10% Conformation. Exhibitors must be 18 years of age or over to qualify for this class.
7. **Gentlemen's Racking Horses:** To be judged 30% Show Walk, 30% Slow Rack, 30% Fast Rack, 10% Conformation. Exhibitors must be 18 years of age or over to qualify for this class.

8. **Amateur Racking Horses:** To be judged 30% Show Walk, 30% Slow Rack, 30% Fast Rack, 10% Conformation. Exhibitors must be 18 years of age or over to qualify for this class.
9. **Open Racking Horses:** To be judged 30% Show Walk, 30% Slow Rack, 30% Fast Rack, 10% Conformation.
10. **Juveniles 13 to 17 Years of Age Racking Horses:** To be judged 30% Show Walk, 30% Slow Rack, 30% Fast Rack, 10% Conformation. All class designated as 17 and under will be required to do three (3) gaits.
11. **Juveniles 12 Years of Age and Under Racking Horses:** To be judged 45% Show Walk, 45% Slow Rack, 10% Conformation.
12. **Lead Line Juveniles 6 Years & Under Racking Horses or Ponies:** To be judged 10% Walk, 40% Overall appearance (including attire) of horse or pony, rider and leader, 40% behavior of horse and rider, 10% Conformation.
13. **Style Racking Horses:** To be judged 45% Show Walk, 45% Style Rack, 10% Conformation, except in open Championship classes to be judged the same as (9) above.
14. **Speed Racking Horses:** To be judged 30% Show Walk, 30% Slow Rack, 30% Fast Rack, 10% Conformation.
15. **Racking Ponies:** To be judged 30% Show Walk, 30% Slow Rack, 30% Fast Rack, 10% Conformation. Ponies 60" and under must be exhibited by a rider 17 years old and under.
16. **Trail Pleasure Racking Horses:** To be judged 45% Trail Pleasure Walk, 45% Trail Pleasure Rack, 10% Conformation/Manners. Horses will be required to back at the call of the adjudicating official.
17. **Western Pleasure Racking Horses:** To be judged 45% Western Pleasure Walk, 45% Western Pleasure Slow Rack, 10% Conformation/Manners. Horses will be required to back at the call of the adjudicating official.
18. **Country Pleasure Racking Horses:** To be judged 30% Country Pleasure Show Walk, 30% Country Pleasure Slow Rack, 30% Country Pleasure Fast Rack, 10% Conformation. Horses will be required to back at the command of the Judge.

19. **Park Pleasure Racking Horses:** To be judged 30% Park Pleasure Walk, 30% Park Pleasure Slow Rack, 30% Park Pleasure Fast Rack, 10% Conformation. Horses will be required to back at the command of the Judge.
20. **Show Pleasure Racking Horses:** To be judged 30% Show Pleasure Walk, 30% Show Pleasure Slow Rack, 30% Show Pleasure Fast Rack, 10% Conformation.
21. **Style Pleasure Racking Horses:** To be judged 45% Style Pleasure Walk, 45% Style Pleasure Rack, 10% Conformation.
22. **Racking Horses To Bike:** To be judged 30% Show Walk, 30% Slow Rack, 30% Fast Rack, 10% Conformation.
23. **Fine Harness Racking Horses:** To be judged 40% Fine Harness Show Walk, 40% Fine Harness Style Rack, 20% Turnout (Performance, Quality, Presence, Conformation and Manners).
24. **Pleasure Racking Horses:** To be judged 30% Brisk Walk, 30% Slow Rack, 30% Extended Rack, 10% Confirmation/Manners. Horses will be required to back at the command of the adjudicating official.

Section 12.2 RACKING SEAT EQUITATION/EQUITATION CLASSES:

1. Racking Horse Seat Equitation was developed especially for the Racking Horse breed and it's particular needs. It is hoped that the trainers and their riders will continue to improve the seat to make it practical and useful, as well as pleasing to the eye:
 - (a) The term "Equitation" specifically means: "The act or art of riding horseback." Equitation for Racking Horses is a very important phase of training and experience for the Racking Horse exhibitor, especially the junior rider. It is an accepted fact that adult exhibitors, amateur, and professional, who have experience in Equitation, make the finest showmen.
2. **Judges:**
 - (a) The Racking Seat Equitation Horse Equitation Judge licensed by the Racking Horse Breeders Association of America, approved by the Judges Committee.

- (b) Racking Seat Equitation Judges and exhibitors are subject to the rules, regulations, penalties, and privileges as set forth by the Racking Horse Breeders' Association of America.

3. General Rules:

- (a) Horses used in this division should be well-groomed and properly tacked.
- (b) Equitation classes are for riders 17 years or younger. The age of the individual on January 1 shall be maintained throughout the entire year.
- (c) Fall of the horse or rider will eliminate the contender.
- (d) Any rider not having their mount under sufficient control shall be dismissed from the ring.
- (e) When workouts are desired, the Judges' instructions to the riders shall be publicly announced.
- (f) Prize Money: Offering of money in Equitation is forbidden, since under the rules covering international sport, a competitor accepting money prizes thereby becomes a Professional. In Equitation classes, the individual is the competitor and wins the award, whereas in other classes the horse is the competitor.
- (g) Ribbons: The awarding of only 6 ribbons is recommended in Equitation classes, regardless of how many ribbons may be awarded in other classes.

4. Basic Guidelines for Judging Equitation Classes:

A. Feet

(a) Stirrup

1. The weight of the rider's foot on the iron should be evenly distributed across the bend (at the ball) of the foot.
2. The size of the stirrup should be 1/4 inch wider than the widest part of the foot.
3. The length of the leather should be according to the length and proportion of the rider's thigh/calf ratio.

B. Heel

- (a) Down at all times, except when spurring a horse whose belly is above the foot of the rider.

C. Toes

- (a) Neither in nor out, but confirming to the anatomy of the rider and his relationship to that individual horse.

D. Feet

- (a) Should be approaching parallel to the horses body.

E. Ankle

- (a) Flexion should be inwards towards the horse.

F. Foot Placement

- (a) Slightly in front of the vertical (an imaginary line drawn from the shoulder thru the hip to the rear of the heel).

G. Calf

- (a) Resting lightly against the horses sides or if the legs are long, dropping straight from the knee perpendicular to the ground.

H. Knee and Thigh

- (a) Resting lightly against the side of the horse.
- (b) Knee always bent.
- (c) Stirrup leather at right to the ground .
- (d) The angle of the thigh to the ground should be approaching 60 degrees.

I. The Seat Weight

- (a) Should lie in the deepest part of the saddle.
- (b) Weight should be evenly distributed between the front pelvic girdle bones and the rear 'seat' bones, equal pressure on the right and left.

J. The Back

- (a) Should always be straight.

K. Chest and Shoulders

- (a) Chest elevated in a proper breathing position.
- (b) Shoulders back.
- (c) Keep the shoulders square with the shoulders of the horse.

L. Head, Neck, Eyes

- (a) Neck straight, head and chin up.
- (b) Eyes forward with a focus approximately 20 feet to the front of the horse.

(c) Pleasing look on face, not grinning or grimacing.

M. The Upper Arm

(a) Lie flat to the sides as naturally as possible, elbows in.

(b) Slightly in front of vertical.

N. The Forearm

(a) Should be parallel to the ground, never above.

O. The Hands and Wrist

(a) Right hand on right rein, left hand on left rein.

(b) 3 to 6 inches apart depending upon the anatomy of the horse and/or rider.

(c) Thumb up with handle angle to the ground approaching 80 to 90 degrees.

(d) Fingers closed around reins, dropping the little finger will be acceptable.

(e) Wrists elastic, with bend to the outside away from the horse.

P. Rein Contact

(a) Medium contact with the mouth.

Q. Whip

(a) Should be carried down.

(b) Held in left hand when tracking to right.

(c) Held in right hand when tracking to left.

R. Horses are not to be considered in equitation classes; however, horses must be registered with RHBA, and perform the gaits of the Racking Horse. Any of the rules or guidelines as set forth for the Racking Seat Equitation Division may be amended by the Judges' Committee with the concurrence of the Board of Directors of the RHBA.

(A.) RACKING SEAT EQUITATION:

1. **Gaits:** Show Walk, Slow Rack, Fast Rack.

2. **Ring Procedures**

a. Enter to the right at a show walk, once around the ring after the gate closed.

b. Slow Rack, once around the ring.

c. Fast Rack, once around the ring.

d. Reverse.

e. Repeat a,b,c.

- (3.) **Splitting of the Class:** It is required that a class of 20 or more be split. Any class under 20 will be at the discretion of the Judge.
- (4.) **Workout:** If a workout is required, the Judge may call for any or all gaits, and horses may be worked both ways of the ring in the gaits requested by the Judge. Workouts shall be considered a separate class and riders will be placed consecutively in the workout. A workout may be called for any place or places.

(B.) TACK:

1. Bridles should be the type commonly used by Racking Horses, with a single pair of reins. Colored brow bands are appropriate; however, rhinestones, etc. are not acceptable. Martingales or similar tie downs are prohibited.
2. Saddles should be of the flat English type, and the correct size for the rider. They should be clean and well kept with the white girth. Forward seat or Western saddles are prohibited.
3. Braids should be neatly attached at forelock and mane. Colors should blend well with the riders habit, brow band and color of horse. Braids should be of the straight plaited variety with no bows or ornamentation.

(C.) APPOINTMENTS:

1. The rider of Racking Seat Equitation is to be judged on his/her skill and form on a horse. The horse and rider should be groomed to perfection. The rider should exercise good taste in choosing habit and accessories.
2. **SUIT:** Should be three piece of a solid conservative color, and is correct both day and evening. Solid colors include black, gray, green, beige, or brown. The cut of the coat, one or two button front with conservative lapels, one vent, with the sleeves striking slightly below the wrist when the arms are brought forward with vigor. The coat tails should be 3 inches longer than fingertips for the female and at the tips for the male. The jodhpurs should be long enough to rest on the

rider's boot top and the bottom of the boot heel when mounted. A moderate fullness is better than a suit that fits to snug.

3. **GLOVES:** Leather, coming just to the wrist
OPTIONAL.
4. **HAT:** Snap brim, male is always covered, female optional; however, girls with long hair should have it styled so that the back number can be easily seen.
5. **BOOTS:** Zippered or side gore, dark color.
6. **TIE:** Conservative as possible with tack.
7. **JEWELRY:** Tiny earrings, no dangles.
8. **SPURS:** As small as possible with straps the color of boots.
9. **SHIRT:** Long collar men's dress plain, preferably white.
10. **FOOT STRAPS:** Should be the same color as suit, of same material as suit, if possible.
11. **WHIP:** 30 inches or shorter.
12. **BELT:** Color of boots, small buckle, plain if needed.
13. **FLOWERS:** None.

Section 12.3 CHAMPIONSHIP/STAKE CLASSES:

Championship classes may be designated in any and all divisions. Percentages for judging shall be the same as in the qualifying class. The only class where saddles shall be required to be removed shall be the Fall World Grand Championship; however, show management of any other show may require removal of saddles in a Championship/Stake class at its option. Except as designated in 12.4 below, whether a horse has to qualify in a previous class in order to be eligible for a Championship/Stake class shall be the decision of show management.

Section 12.4 FALL WORLD CHAMPIONSHIP: Any horse which has shown in a previous class, except for Pleasure and Specialty Action Classes, is eligible to show in the World Grand Championship. In other Championships at the Fall Celebration, in order to show in a Championship restricted by age of the rider or horse, size of the horse, or status of the rider, the horse must have qualified in a previous class so restricted. (2/19/05)

Section 12.5 HALTER CLASSES: Entries shall be led wearing a show bridle or show halter, and may be lined up at the discretion of the Judges. Horses must be shown in hand at a brisk walk. Consideration is given to type, conformation, substance and quality. Exhibiting a gait may be asked for at the Judge's discretion. Weanlings and Yearlings must be shown in a show halter only. Shows may divide classes by age and/or sex at their discretion.

a) Handling Procedure

1. Both horse and handler must be properly presented. In addition to appearance and conformation, the animal will be judged on his potential to execute the gait. Move out at a **brisk** heel-to-toe walk to best demonstrate your horse's ability.
2. Show the horse and not yourself. Be natural. Overshowing, undue fussing and maneuvering are objectionable. When posing your horse, stand toward the front facing the horse, but not directly in front of the horse, positioning yourself where you can keep your eye on the Judge.
3. Do not crowd the exhibitor next to you when in a side position.
4. When the Judge is observing other horses, let your horse stand at ease if reasonably well posed,
5. Keep alert and be aware of the position of the Judge at all times. Do not be distracted by persons or things outside the ring.
6. Respond quickly to requests from judges and officials.
7. Be courteous and sportsmanlike at all times.
8. Recognize and quickly correct faults of your horse.
9. Keep showing until the entire class has been placed or excused from the ring.

b) Fitness and Conditioning: A Halter horse should be a picture of good health, neither too fat nor too thin. The horse should be bright-eyed and alert. The horse will be immaculately groomed with ears and mane trimmed, hoofs painted and ribbons properly affixed.

c) Manners/Behavior: Halter horses will be well mannered and under control at all times. Ill-tempered or unruly horses shall be dismissed by any Judge.

- d) **Drugs:** Drugs or medication shall be administered only with the approval of the show veterinarian. Any animal that demonstrates signs of being tranquilized will not be considered for judging.
- e) **Show Ring Procedure:** The size of the exhibition area of the ring may be modified at the discretion of show management.

Section 12.6 CONFORMATION JUDGING

- (1.) In conformation judging, the horses are to be lined up head-to-tail around the ring in a clockwise direction, spaced at a safe distance apart.
- (2.) Enter the ring leading the horse at an alert and brisk walk in a counter-clockwise direction. Only one handler per horse is allowed. Every horse will be required to make a complete circle around the exhibition area of the ring in both directions in each workout.
- (3.) Weanling and Yearlings will be shown in show halters with no bits being allowed. Two-Year-Olds and older horses may be shown in show halter or show bridle at the discretion of the handler.
- (4.) In the line-up, Racking Horses will be posed with their front legs perpendicular to the ground and their hind legs stretched slightly behind them.
- (5.) **Appointments:**
 - 1. Show halters and leads should be of all leather construction with a chain lead. The brow band should match the ribbons and not clash with the handler's attire. Ornately decorated halters are not appropriate for the showing of Racking Horses. Bridles shall be of the type commonly used on Racking Horses. Ribbons shall be neatly attached at the forelock and mane. All tack must be immaculately clean.
 - 2. Exhibitor will wear an English riding habit that is neat and properly fitted. Coat shall be required unless specified otherwise by show management. Sequins, rhinestones, loud colors, and flashy costumes are not appropriate for showing Racking Horses at halter.
- (6.) Horses shown at halter may or may not be shod, at the

discretion of the handler. Horses that are shod must be shod neatly and in a professional manner. Shoeing must conform to Racking Horse and USDA Regulations.

Section 12.7 YEARLING and WEANLING SHOETING

- (a) Yearlings shall be permitted to be shod with a buildup not to exceed one (1) inch, excluding the shoe measured at the back (thickest part), which shall be no larger than 3/8 inch thick and 3/4 inch wide and weigh no more than 16 ounces. No lead may be added to the pads .
- (b) Shoes on weanling are prohibited.

Section 12.8 GUIDELINES FOR JUDGING FUTURITY HALTER CLASSES

(a) Areas of Judging:

1. Conformation: 40% on the rail at a **brisk walk**, 30% on the lineup.
2. Showmanship and Handling: 20%
3. Manners and Grooming: 10%

(b) Points for Judging: Foals are judged when all entries have entered the ring at a brisk walk. Foals should be judged on their potential to execute the desired gait. Exhibiting a gait may be requested at judge's discretion.

(c) Conformation: Ideal conformation permits foal to move with rhythmic motion showing coordination from head to tail. The stride should be long but collected, not awkward or clumsy. The head motion is synchronized with motion of the body. The head should be high and alert, but not stiff or restrained, with eyes bright and ears up and forward. The short jigging walk, or gait, is not wanted or desired. The feet should hit the ground firmly. Back feet should trail front feet in line without winging in or out. The rear legs should stride far under the foal to give an impression of driving strength, but not to the extent of causing in-coordination of total movement.

(d) Showmanship and Handling: Handler should show his/her foal, but not himself. The foal should be trained well enough so that the handler does not have to use excessive

restraint. He/she should allow the foal freedom to exhibit at its best.

- (e) **Manners and Grooming:** Allow foals from one-half to one lap around ring to settle down and adjust to the crowd and strange environment. After this time, count off for poor manners, particularly if there is interference with other entries. Consider excusing unruly entries. Foals should be well groomed and in show condition.
- (f) **Conformation Judging Continued in the Line-Up:** Line foals up head-to-tail around the ring. Head should be up and alert, eyes showing interest and ears up and forward. The foal should stand slightly extended on a well-proportioned bone. The body should show good muscling under a pliable hide, allowing for easy movement. The neck should come out of the shoulders at an angle that allows the neck and head to be held high naturally. The neck should have well-proportioned length and depth. The throat latch is small, but large enough to allow easy breathing. The back is short and straight, blending well at withers and hips. The body is deep with good spring of ribs and carries smooth muscling. The rump is long with good slope hip to tail. Good muscling should be evident. The legs should have good bone, but not coarse, standing straight on front, not turned in or out. Rear legs should be well muscled to hock. Hock angle should allow rear legs to stride forward, well under foal, but not cow-hocked. The feet are well-proportioned to weight of foal.

Section 12.9 SANCTIONED CLASSES:

- (a) It is realized by the Racking Horse Breeders' Association of America that all localities of the United States will not have the same general interests regarding Racking classes; however, it is suggested that at least one class of the following nine (9) Divisions be included in each show:
 1. Trail Pleasure
 2. Country Pleasure
 3. Western Pleasure
 4. Pleasure Racking
 5. Park Pleasure

6. Show Pleasure
7. Style Pleasure
8. Flat Shod
9. Open Shod
10. Juvenile

Should horses not be in enough numbers to warrant all Divisions, it is suggested that as many of the Divisions as possible be included in affiliated/sanctioned shows.

- (b) The following are classes from which show management may choose in the setting of scheduled classes (variations of or deviations from the suggestion are permissible:

1. TRAIL PLEASURE

- (a) Trail Pleasure, Juvenile
- (b) Trail Pleasure, Ladies
- (c) Trail Pleasure, Gentlemen
- (d) Trail Pleasure, Open
- (e) Trail Pleasure, Stake or Championship

2. COUNTRY PLEASURE

- (a) Country Pleasure, Juvenile
- (b) Country Pleasure, Ladies
- (c) Country Pleasure, Gentlemen
- (d) Country Pleasure, Open
- (e) Country Pleasure, Stake or Championship

3. WESTERN PLEASURE

- (a) Western Pleasure, Juvenile
- (b) Western Pleasure, Ladies
- (c) Western Pleasure, Gentlemen
- (d) Western Pleasure, Open
- (e) Western Pleasure, Stake or Championship

4. PLEASURE RACKING

- (a) Pleasure Racking, Juvenile
- (b) Pleasure Racking, Ladies
- (c) Pleasure Racking, Gentlemen
- (d) Pleasure Racking, Open
- (e) Pleasure Racking, Stake or Championship

5. PARK PLEASURE

- (a) Park Pleasure, Juvenile
- (b) Park Pleasure, Ladies
- (c) Park Pleasure, Gentlemen
- (d) Park Pleasure, Open
- (e) Park Pleasure, Stake or Championship

6. SHOW PLEASURE

- (a) Show Pleasure, Juvenile
- (b) Show Pleasure, Ladies
- (c) Show Pleasure, Gentlemen
- (d) Show Pleasure, Open
- (e) Show Pleasure, Stake or Championship

7. STYLE PLEASURE

- (a) Style Pleasure, Juvenile
- (b) Style Pleasure, Ladies
- (c) Style Pleasure, Gentlemen
- (d) Style Pleasure, Open
- (e) Style Pleasure, Stake or Championship

8. FLAT SHOD

- (a) Any class that bears "Flat Shod" as the definition of its shoeing requirements

9. OPEN SHOD

- (a) Two-Year-Old (can be broken down by sex of the horse)
- (b) Two- and Three-Year-Old combination classes (refer to Section 12 1(b))
- (c) Three-Year-Old (Can be broken down by sex of the horse)
- (d) Four-Year-Old (Can be broken down by sex of the horse)
- (e) Lady riders, Amateur
- (f) Gentlemen riders, Amateur
- (g) Style Racking, Ladies/Gentlemen, Amateur
- (h) Style Racking, Open

- (i) Juveniles on Racking Horses (see Article X, Section 10 6(a) for specification for Junior and Senior Juveniles)
- (j) Speed Racking, padded and/or flat shod
- (k) Amateur Owned & Trained
- (l) Amateur, Open
- (m) Aged Mares
- (n) Aged Stallions, Geldings
- (o) (15) 15 2 and Under
- (p) Ponies, 60" and Under
- (q) Racking Horse to Bike
- (r) Racking Horse to Fine Harness
- (s) Stake classes

Section 12.10 UNAUTHORIZED ENTERING OF CENTER

RING: Other than those officials authorized to be in center ring, no one may enter center ring, for any reason, at an RHBAA affiliated/sanctioned show without express permission by authorized official. (Exception: persons eligible to enter center ring for winners' presentation pictures, Article VIII, Section 8.17(a).)

Section 12.11 RETIREMENT CEREMONIES: Horses being officially retired at any appropriate ceremony, whether on a national level or state level, will be deemed ineligible for further competition in the particular division or class that represents the retirement ceremony. World Grand Champion being officially retired at any appropriate ceremony shall be deemed ineligible for competition in all divisions. This rule shall be applied retroactively.

ARTICLE XIII

SHOW OFFICIALS AND RESPONSIBILITIES

Section 13.1 GENERAL: The attention of the show officials at any affiliated/sanctioned show recognized by the Racking Horse Breeders' Association of America should be given to the current edition of Rules and Regulations as published by the Racking Horse Breeders' Association of America, and each official should be intimately aware of and enforce all rules and regulations pertaining

to exhibition and/or guidelines as suggested by the Racking Horse Breeders' Association of America. It is also understood that no definition of show officials or show management can adequately cover the responsibilities of each officer of any show, and, that in many instances, common judgment must be exercised. In such events that require immediate decisions, the rule that most applies to a given problem shall be the solution, and the Racking Horse Breeders' Association of America shall not be held responsible for any decision regarding an exhibitor, owner, or any person connected with the promotion and execution of a show or held responsible for any mismanagement, financial or otherwise.

- (a) **Show Chairman:** The Show Chairman of a recognized show shall be responsible for the operation and execution of the show. He may act as a referee in times of decision and should be intimately aware of, and enforce all rules of, the Racking Horse Breeders' Association of America.
- (b) **Show Manager:** Affiliated/sanctioned shows should exercise extreme care in the selection and appointment of a Show Manager for the mutual benefit of all committees, exhibitors and spectators. A complete and thorough knowledge of the Rules of the Racking Horse Breeders' Association of America shall be one of the requisites of a person serving as Show Manager. Any Show Manager who willfully violates or knowingly permits a violation of the Rules of the Racking Horse Breeders' Association of America at his show shall be subject to disciplinary action by the Racking Horse Breeders' Association of America, and suspension of privileges may be effected at the discretion of the Racking Horse Breeders' Association of America. A Show Manager may be eligible to be the recipient of a protest during a show regarding his decisions. A Show Manager may not serve as Judge, Ringmaster or Steward of his own show, and in all cases must report to the Show Chairman regarding all show events that require expert judgment.
- (c) **Show Committees:** Show committees should be appointed according to the needs of the show. Examples of committees that can be effectively utilized for the benefit of a show are as follows:

1. Finance
 2. Advertising
 3. Grounds
 4. Stabling
 5. Entertainment
 6. Personnel
 7. Judges Committee
- (d) **Show Secretary:** The Secretary at any affiliated/ sanctioned show should have in his/her possession at all times a copy of the current book of Rules and Regulations. The Secretary shall report to the Show Manager/Show Chairman any discrepancies that may occur at any affiliated/ sanctioned show, and be responsible for the fluency of entries and/ or smooth running of the show. Proper accounting of finances, premium distribution and any other clerical duty as required by the Show Manager should fall to the Show Secretary. This is a position of extreme importance, and it is imperative that a knowledgeable person be placed in this category.
- (e) **Ringmaster:** A Ringmaster may not officiate in any division of a show in which he or a member of his family, or any of his clients is an exhibitor. His sole duty shall be to assist the designated Judge when needed, and to accept requests such as “time out,” etc. and to escort in a safe manner any person, such as Ribbon Presenter, whose presence is required in the center ring. In no case shall a Ringmaster advise a Judge of anything other than an infraction of the Rules, and in no case shall a Ringmaster officiate where a horse either wholly owned or partially owned is allowed to compete in a sanctioned show where the owner is serving the capacity of Ringmaster.
- (f) **Steward:**
1. A Steward must have full knowledge of the Rules of the RHBAA. He **must** report to show management any offense or violation of the Rules and **must** also prefer charges to the RHBAA against any exhibitor who conducts himself in a manner that violates the Rules of the RHBAA.
 2. A Steward may not officiate in any division of a show in which he or a member of his family or any of his clients

is an exhibitor. A Steward has no authority regarding the management or the judging of an affiliated/sanctioned show; however, he is the representative of Show Management, and should point out in a diplomatic and courteous manner any set of circumstances where Racking Horse Breeders' Association of America Rules are not enforced.

3. A Steward should not dictate to the Judges or management but should immediately report to show officials any violations of the Rules which might invalidate or cause protest to a class. He should keep himself available to Judges, exhibitors, and management at all times to clarify the position of the Racking Horse Breeders' Association of America Rules and investigate any situation that might indicate an infraction of the Rules.
4. Other duties of a recognized Steward shall be, but are not limited to the following:
 - (a) Protect the interest and reputation of the show.
 - (b) Protect the interest of exhibitors, Judges and Show Management.
 - (c) Provide measurement in specified height classes (Example: Pony, 15.2 & Under classes).
 - (d) Report to Show Management any offense or violation of the rules and regulations and prefer charges to the Racking Horse Breeders' Association of America against any exhibitor who conducts himself/herself in a manner that does not reflect good taste.
 - (e) Make himself available to the general public for advice and/or assistance.
 - (f) Determine humane treatment to horses on the grounds and during exhibition.
 - (g) Current Rules and Regulations do not specify the entry steward as a requirement for an affiliated/sanctioned show; however, show manpower avail itself, and if the need arise, it is suggested that a knowledgeable person be appointed providing Show Management feels a need for this official.

- (g) **Paddock Master:** A Paddock master is an important member of Show Management and is responsible to the Show manager for the fluency of class entries, and performs other duties such as supervising ring entry and ring departure of horses.
- (h) **Farrier:** It is suggested that a Farrier be available during all performances. He shall report promptly when called to the ring to make repairs during a class. He shall conduct himself in a manner reflecting good taste and shall act as a show official representing the management of the show in his every action. A Farrier shall not charge the exhibitor for his services when called upon to replace a shoe in the center ring; however, if further services are required outside the ring in order to permit the exhibitor to show in another class, charges will be in order.
- (i) **Veterinarian:** It is suggested that a qualified Veterinarian be on the grounds, or in a position easily reached by Show Management, in the event of an emergency.
- (j) **Responsibilities of Show Management:** The terminology “Show Management” shall refer to the personnel representing the charity or the sponsoring organization. It is suggested that Show Management insure the following:
1. Employ qualified personnel for manning the important posts such as Judge, Master of Ceremonies. Determine that the Judge shall hold a current license and be well respected among his peers.
 2. Properly affiliate with the RHBAA by completing all forms and paying all fees required, both to the RHBAA and to the National Horse Show commission, or other regulatory body. Show management should communicate with the RHBAA office to ascertain that all requirements for affiliation will be met.
 3. Secure the services of a competent Steward should the need require the services of a qualified person.
 4. Secure a qualified Ringmaster.
 5. Provide all necessary physical facilities to accommodate exhibitors, such as restroom facilities.
 6. Provide for stalls. In the event stall facilities are limited, it is suggested that out-of-state guests be housed first.

7. Provide for motel accommodations.
8. Accept responsibility to insure that all rules, regulations and procedures stated in the Racking Horse Breeders' Association of America Rule Book are followed.
9. Provide the services of a qualified Veterinarian, or have easy access to his services.
10. Provide for emergency medical services, or be in a position to have immediate access to ambulance service, etc.
11. Provide a Farrier on the grounds at all shows.
12. Abide by all decisions made by a Judge at all shows.
13. Take steps to insure that all entries in classes that require measurements are in compliance with the rules. It is imperative that show officials resolve any protest regarding measurements.
14. Take steps to insure that all entries in classes that require measurements are in compliance with the rules. It is imperative that show officials resolve any protest regarding measurements.
15. Take steps to insure the personal safety of all officials of your show, and extend the courtesies generally expected.
16. Advise exhibitors of all changes in the program regarding class structure.
17. No Show Manager may serve as a Judge.
18. Provide a representative selection of classes from each Division, if possible.
19. It shall be the sole responsibility of Show Management to allow for the return of entry fee if a horse has been properly entered in a class, and did not show. The return of fee is strictly at the discretion of Show Management.
20. **It shall be the responsibility of Show Management at any affiliated/sanctioned event to fully comply with all United States Department of Agriculture Rules and Regulations relating to Public Law 91-540, known as the Horse Protection Act of 1970, revised edition May 17, 1989.** The term "affiliated/sanctioned event" shall also include those activities other than

horse shows, such as sales and/or dispersals, and is further defined as being a part of any horse related activity relating to Public Law 91-540, revised edition dated May 17, 1989.

Section 13.2 SUGGESTIONS TO PROMOTE A SUCCESSFUL HORSE SHOW

1. Printing of tickets; advance ticket sales.
2. Promote the sale of advertising for show program.
3. Careful selection of classes.
4. Printing of program and/or class schedules.
5. Mailing of class schedules and personal contacts inviting owners, exhibitors and trainers to show.
6. Advertise motel and hotel facilities, if available.
7. Advertise stable facilities, if available.
8. Advertise in conjunction with other shows, if possible
9. Pass out class schedules at other shows prior to your show and request their Master of Ceremonies to announce your show date.
10. Send show date to industry media, local newspapers, radio and TV stations.
11. Provide ample parking for exhibitors and warm-up area for exhibitors/trainers.
12. Provide ring fence that will not impair vision of spectators.
13. Provide adequate sound system.
14. Provide a ring for showing that has both exit and entrance.
15. Provide proper and sufficient lighting in ring and truck parking area .
16. Track should be smooth and firm.
17. The Celebration show ring is 150' wide by 300' long. Show ring should be constructed as nearly as possible to this size and sharp turns should be eliminated.
18. Arena should be attractively decorated. Enlist aid of florist.
19. Provide ample seating.
20. Police protection should be available.
21. Select knowledgeable and courteous gate personnel.
22. Provide ample restroom facilities.
23. Provide for proper traffic control and directions.
24. Have clean grounds and cut grass.

25. Provide transportation for out-of-town officials.
26. Sufficient directional signs to show grounds should be posted.
27. Obtain efficient and knowledgeable secretary.
28. Insure that names of entries, exhibitors and owners are correct and legible on entry sheets This helps the announcer and assists in proper records.
29. Obtain experienced horse show organist.
30. Have electrician available.
31. Obtain knowledgeable ringmaster.
32. Obtain experienced farrier.
33. Obtain competent and knowledgeable Master of Ceremonies who is experienced in working horse shows.
34. Acquire sufficient entry forms and Judges' cards.
35. Include classes of local interest.
36. Appoint a Hospitality Committee to show appreciation to exhibitors and other visitors.
37. Promote Exhibitors Party if possible.
38. Provide food at reasonable prices.
39. Select attractive trophies and ribbons.
40. Offer adequate prize money.
41. Proper ratio between prize money and entry fees, not to exceed 20 percent of first prize.
42. Back numbers large enough to be easily seen.
43. Keep show moving; eliminate all lulls possible.
44. Complete as many duties as possible prior to show.
45. Affiliate/sanction with the Racking Horse Breeders' Association of America and affix the trademark on all literature and advertising.
46. Select a show date that will not conflict with another show within 50 miles.
47. Engage a competent photographer.

ARTICLE XIV

ADVISORY BOARD

Section 14.1 GENERAL: The Advisory Board is composed of members from throughout the United States and is primarily concerned with the proper technique, policy and implementation of directions received from the RHBAA Board of Directors. A Vice President of the RHBAA, elected by and from the RHBAA Board of Directors, shall serve as Chairman of the Advisory Board. All Committees shall report their activity to the Advisory Board three times per year. Directions may be given to the Committees by the Advisory Board at the discretion of its Chairman. In order to better facilitate operation and make each Committee more efficient, each Committee has the freedom of direct communication with the Board of Directors; however, each Committee's chairman also will report on its progress to the Advisory Board. The Advisory Board also serves the Board of Directors in its efforts to promote the Racking Horse industry through recommendations received from Members, trainers, owners, exhibitors, and those who are interested in the Racking Horse as a means of pleasure, showmanship or breeding. All decisions made by the Advisory Board are submitted to the Executive Committee and then to the Board of Directors for its approval and, once approved, become a part of the Rules. Notification of modifications, additions or deletions to the Rules will be provided to the membership.

ARTICLE XV

PERSONNEL AND PROPERTY COMMITTEE

Section 15.1 GENERAL: The Personnel and Property Committee of the Racking Horse Breeders' Association of America shall be chaired by a Vice President elected by and from the Board of Directors and shall consist of one additional member of the Board of Directors. Other members of this committee shall be selected by the Chairman and ratified by the Board of Directors. The mission of the Personnel and Property Committee is to insure that the RHBAA has adequate and competent staff to carry out the goals and objectives

stated in the Articles of Incorporation and Bylaws of the RHBAA; and said committee shall see that the property of the RHBAA is properly maintained and insured. This committee shall also make recommendation to the Board of Directors concerning the use and condition of the land and buildings of the RHBAA. The Personnel and Property Committee shall serve the Board of Directors through the President and Executive Director in an advisory capacity and shall oversee the property of the RHBAA. This Committee may have additional duties assigned by the Board of Directors.

ARTICLE XVI

DQP COMMITTEE

Section 16.1 COMPOSITION: The DQP Committee shall consist of the Chairman, who shall be elected annually by the Board of Directors as are all other permanent vice presidents, and the following other persons: the other primary representative or representatives (not including alternates) to the National Horse Show Commission as appointed by the Board of Directors; and such other members of the RHBAA who may be initially appointed by the Chairman of this Committee, but who must be confirmed and approved by the Board of Directors.

Section 16.2 PURPOSE: The purpose and duties of the DQP Committee shall be to keep abreast of, and to keep the RHBAA Board of Directors advised as to the Horse Protection Act developments, including the interpretation and implementation of the enabling Code of Federal Regulations by APHIS and the USDA and all agreements and rules covering the inspection of horses, penalties for violations, as well as the activities of the National Horse Show Commission and of the participation by the RHBAA therein. It shall also be the responsibility of this Committee to study the advisability and feasibility, or not, of the RHBAA forming its own Horse Industry Organization under the regulations of the United States Department of Agriculture, including making an evaluation, study, and recommendation to the Board of Directors as to the cost to the RHBAA of such an operation, how such an operation would be funded, and a proposal as to its organization and operation.

The Committee is also charged with the responsibility of preparing and having in readiness all documents and other things necessary for the submission for approval to the USDA as quickly as can be reasonably accomplished following a possible decision by the Board of Directors of the RHBAA to become a recognized Horse Industry Organization certified by the USDA to operate its own DQP Program.

ARTICLE XVII

NATIONAL RULES ENFORCEMENT COMMITTEE

Section 17.1 GENERAL: The National Rules Enforcement Committee will have a total of five members and the Chairman. The members will be selected as follows: (a) The President of the Pleasure Association; (b) The President of the Trainers Association; (c) The President of the Amateur Association; (d) The President of the Futurity Association; (e) A Board Member “Co-Chairman.” The Chairman will only vote to break a tie.

Section 17.2 PERSONS BOUND BY RULES: Any applicant for membership in the RHBAA, and any non-member who affords himself/herself or itself of any other privilege of the RHBAA, in so doing agrees to be bound by the Articles of Incorporation, Bylaws and Rules of the RHBAA. Any Member and any non-member who exercises any privileges of the RHBAA or engages in any of the activities encompassed thereby, including without limitation the buying, selling, breeding, registration, showing exhibiting or engaging in any other activity relating to the RHBAA, may be disciplined for violation of any Rule or provision of the Articles of Incorporation or the Bylaws, in accordance with the provisions of the Bylaws and the Rules. The Rules Enforcement Committee shall be responsible for making all final determinations concerning Class A, B, C, and F violations of the Rules, and for rendering initial determinations regarding Class D and E violations. Full investigative powers are vested in the Rules Enforcement Committee. The Racking Horse Breeders’ Association’s Board of Directors shall serve as a final appeal body for Class D and E violations.

Section 17.3 PRELIMINARY ENFORCEMENT, PROCEDURE

- a. Show Managers shall be responsible for interpretation and enforcement of the Rules at that particular show insofar as conducting the show in accordance with the Rules of the RHBAA. In order to enforce this authority, Show Management may prohibit any exhibitor from showing or further participating in the show, and may take other such steps as may be necessary to require compliance by the participants at the show with the Rules and Bylaws of the RHBAA.
- b. Any Member of the Racking Horse Breeders' Association of America may, in good faith, file a protest against any exhibitor, agent, trainer, breeder, judge or juvenile exhibitor's parent, alleging a violation of the Rules. Such protest must be presented in writing, signed and accompanied by a filing fee in an amount set from time to time by the Board of Directors of RHBAA. Any protest filed by a member must be filed with the National Rules Enforcement Committee and postmarked within one week of the alleged violation. The protest must state the full name and address of the charged party and must contain a full and definite statement concerning the alleged violation of the Rules.
- c. All permanent committees have the duty to report any alleged violations of the Rules of the RHBAA to the Rules Enforcement Committee for investigation by it and possible further action; however, each committee shall have the right to do its own investigation into any such alleged violations falling within the scope of that committee's functions, powers and duties in order to determine if there may be sufficient merit to any such allegation to warrant reporting the same to the Rules Enforcement Committee. The decision of any permanent committee as to whether to report or not report any such allegations to the Rules Enforcement Committee shall not be binding in any way on the authority of the Rules Enforcement Committee to conduct its own investigation and to make its own determination as to whether probable cause exists for a hearing to be held regarding such alleged violation as set out hereinafter.

- d. The Rules Enforcement Committee, acting on its own, may conduct an investigation of any matter coming to its attention regarding possible rules violations of the Rules of the RHBA; and, if the Rules Enforcement Committee determines that probable cause exists that such violations did in fact occur, the Rules Enforcement Committee shall notify the person alleged to have committed such violations of the alleged violations and of his right to a hearing concerning such allegation.
- e. Any notice required to be given to a member of the RHBA under Article XVII of these Rules shall be deemed to have been properly given if such notice is mailed in the United States mail by certified mail, return receipt requested, restricted delivery, addressed to said member at the last address given by the member to the RHBA office, and said signed receipt is returned, or the envelope is returned marked "refused." The date of such notice shall be the date the receipt is signed or the date the envelope is stamped "refused."

Section 17.4 HEARING BEFORE RULES ENFORCEMENT COMMITTEE

- a. When a protest is filed with the Rules Enforcement Committee by a member of the RHBA or upon a determination by the Rules Enforcement Committee that probable cause does exist, that a violation of the RHBA rules has occurred (and the Rules Enforcement Committee may, but does not have to, rely on the recommendations of any permanent committee as to probable cause), the Rules Enforcement Committee shall within a reasonable time notify, in writing, the person against whom the protest or allegation is reported. Such notice shall be sent by certified mail, return receipt requested, restricted delivery. The recipient shall then have 15 days after the date of receipt of notification to request a hearing to respond to the allegations. Such a request for hearing shall be in writing, shall be submitted to the Rules Enforcement Committee, and shall include payment of a filing fee in amount set from time to time by the Board of Directors of the RHBA. A recipient of notice

who fails to request a hearing concerning alleged Class D and E violations shall have no right to appeal the Rules Enforcement Committee's decision to the RHBAA Board of Directors.

- b. If no written request is received by the Rules Enforcement Committee within such 15 days, it shall consider the protest or allegation and make a decision with respect thereto based upon the information available to it.
- c. The Rules Enforcement Committee, upon receiving the filing fee and request for hearing, shall set a date for the hearing and notify the respondent of the date, time and place of such hearing. The Rules Enforcement Committee shall meet no less than once each quarter to consider alleged violations.
- d. If a hearing is requested in a timely fashion, no penalty or sanction shall be imposed upon the respondent until the requested hearing is held. If the Rules Enforcement Committee shall determine in good faith, however, that any protest filed by a person is frivolous, the Rules Enforcement Committee may levy such additional penalties against such person making the protest as it deems appropriate.
- e. All determinations by the Rules Enforcement Committee shall be final and non-appealable, except for those with respect to Class D and E violations, as set forth herein.

Section 17.5 PROCEDURE FOR APPEAL TO THE RHBAA BOARD OF DIRECTORS TO REVIEW CLASS D AND E VIOLATIONS

- a. The Rules Enforcement Committee shall mail a written copy of its decision to the respondent within 15 days of its having reached such decision. Persons determined to have committed a Class D or E violation shall be required, in order to appeal, to request such appeal in writing within ten (10) days after receiving written notice of the National Rules Enforcement Committee's decision, and include payment of a filing fee in an amount set from time to time by the Board of Directors.
- b. If no written request for a review is received by the Racking Horse Breeders' Association's Board of Directors within

ten (10) days, the party upon whom the penalty has been imposed shall be deemed to have accepted the penalty without protest and shall have no right to appeal the penalty.

- c. Upon receipt of an appeal request and the filing fee, the Racking Horse Breeders' Association's Board of Directors shall meet no less frequently than once each quarter to consider such appeals.
- d. In conducting review of a penalty which has been appealed, the RHBAA's Board of Directors shall consider only issues and evidence which were presented to the National Rules Enforcement Committee during the prior hearing. The Racking Horse Breeders' Association's Board of Directors shall not consider any new issues or other testimony or evidence which was not properly before the National Rules Enforcement Committee earlier, except that this section does not prohibit a petitioner from introducing evidence or testimony which was unavailable to the petitioner at the time of the earlier hearing through no fault or neglect of the petitioner at the time of that hearing.
- e. After the review is held, the RHBAA Board of Directors shall either affirm the penalty imposed by the National Rules Enforcement Committee or, in its own discretion, modify or remove the penalty; except that the Board of Directors on the question of the guilt or not of the petitioner (as opposed to the penalty assessed) shall affirm the finding of the Rules Enforcement Committee unless the Board affirmatively finds that the decision of the Rules Enforcement Committee as to the guilt of the petitioner was against the great weight of the evidence and was manifestly wrong.
- f. The RHBAA Board of Directors shall deliver a written copy of its decision to the petitioner within ten (10) days of its having reached such a decision. The written copy shall be sent by United States mail by certified mail, return receipt requested, restricted delivery.
- g. All decisions of the RHBAA's Board of Directors are final and non-appealable.

ARTICLE XVIII

RULES VIOLATIONS, PENALTIES and PROCEDURE

PART A - VIOLATIONS

Section 18.1 EXHIBITOR, OWNER, TRAINER, BREEDER AND MEMBER VIOLATIONS

Commission of the following violations will subject an exhibitor, owner, trainer, breeder or Member to penalties. Violations have been categorized by Class as indicated in brackets following each violation. The maximum penalties corresponding to each violation are set forth in **PART B** hereof:

- a. Exhibitor showing a Racking Horse before a Judge within a 30-day period of Judge's receiving remuneration for services rendered to owner (of horse being shown) **[A]**
- b. Exhibitor showing a Racking Horse before a judge whose spouse or immediate family renders professional service relative to preparing the horse to compete or has rendered services within 30-day period for which he/she receives remuneration **[A]**
- c. More than one person riding horse on victory pass **[A]**
- d. Showing a Racking Horse in an improper classification other than with respect to an age classification **[A]**
- e. An exhibitor's failure in bad faith to bring a mount to a complete stop prior to receiving a presentation **[A]**
- f. An exhibitor's dismounting at any sanctioned event unless given permission by the presiding ringmaster. Exception will be made for those exhibitors who lose control of their mounts. Exception also will be made for those exhibitors called to the center ring immediately prior to a workout, who may voluntarily dismount and check equipment before being called to the ring for further judging **[A]**
- g. Showing in a class without a current Exhibitor Show Card **[A]**
- h. Having a Racking Horse dismissed from class for displaying a bad image in accordance with the National Horse

Protections Act. Penalties apply equally to trainer and exhibitor. Suspension also applies to horse First offense **[A]**

- i. An exhibitor, owner, trainer or member approaching a judge with regard to a tie **[B]**
- j. Communication with a Judge for purposes of obtaining information about a future tie, once the Judge's appointment is announced by the show management **[B]**
- k. Exhibition of a Racking Horse at any Racking Horse Breeders' Association of America affiliated/sanctioned show by personnel involved in center ring activity at such show, including, without limitation, ringmasters, stewards, masters of ceremonies, photographers and scorers, whether such personnel receive remuneration or work as volunteers **[B]**
- l. A show manager's willfully or knowingly permitting a violation of the rules at a show for which such show manager is responsible **[B]**
- m. The second offense during a calendar year of having a Racking Horse dismissed from class for displaying a bad image in accordance with the National Horse Protection Act. Penalties apply equally to trainer and exhibitor. Suspension also applies to horse **[B]**
- n. Showing a Racking Horse out of its proper age classification **[C]**
- o. Unauthorized person entering center ring, for any reason, at an RHBAA affiliated/sanctioned show, without express permission **[C]**
- p. Engaging in conduct in a fashion that is considered unbecoming, ungentlemanly or unladylike **[C]**
- q. Exhibitor, professional trainer, or agent thereof, including the horse involved, who violates any rule of the Amateur Owned and Trained Division **[C]**
- r. An owner's acting as ringmaster or steward at a show at which a horse in which he has an ownership interest is competing **[C]**
- s. The third offense during a calendar year of having a Racking Horse dismissed from class for displaying a bad image in accordance with the National Horse Protection Act. Penalties apply equally to trainer and exhibitor. Suspension also applies to horse **[C]**

- t. Any exhibitor, owner or Racking Horse engaging in any and all activities or events sanctioned by or affiliated with the Racking Horse Breeders' Association of America and/ or the National Horse Show Commission while on suspension **[C]**
- u. Giving a false statement to the Rules Enforcement Committee during the course of an investigation or hearing knowing said statement to be false and making it with the intent to deceive **[D]**
- v. RHBAA horses showing in the Specialty Action Classes are permitted to use an action device that is in compliance with HPA. Any action device used other than the ones permitted by the HPA will be a violation of the rules. Other Divisions using any artificial substance or mechanical device, including, without limitation, chains, trotting balls and action devices, in showing a Racking Horse in any racking class in any show regardless of whether such show is affiliated/ sanctioned by the Racking Horse Breeders' Association of America or on the show grounds of the RHBAA, or at any public area (such as warm-up area, staging area, etc) at any RHBAA sanctioned show, or treating a Racking Horse in an inhumane fashion on any show grounds shall be in violation **[D]**
- w. Fraudulent conduct of any kind regarding the registering, showing or selling of an Racking Horse, or any other fraudulent conduct committed in the course of dealing in the Racking Horse industry **[D]**
- x. The administering or providing to a Racking Horse of any drug or medication that would in any way act as a depressant or a stimulant in competition, by oral feeding, injection or otherwise Exceptions include simple medications for common colds or injections as prescribed by a qualified veterinarian at the owner's or trainer's premises or at a Racking Horse Breeders' Association of America affiliated/ sanctioned show, should the need arise Should injections or medications be required on the show grounds prior to a class participation, show management must be advised well in advance of administration of drugs or medication **[D]**

- y. Showing a horse that is not registered with the Racking Horse Breeders' Association of America in any Racking Horse class at a show affiliated/sanctioned by the Racking Horse Breeders' Association of America **[D]**
- z. A professional's knowingly and falsely representing himself or herself as an amateur in order to ride in Amateur classes **[D]**
 - aa. The fourth offense during a calendar year of having a horse being dismissed from class for displaying a bad image in accordance with the National Horse Protection Act Penalties apply equally to trainer and exhibitor Suspension also applies to horse **[D]**
 - bb. Willfully registering or attempting to register, recording or attempting to record, a false pedigree, or willfully falsely commissioning a Racking Horse **[E]**
 - cc. Obtaining certificates by fraud or misrepresentation **[E]**
 - dd. The fifth offense of having a horse dismissed from class for displaying a bad image in accordance with the National Horse Protection Act Penalties apply equally to trainer and exhibitor Suspension also applies to horse **[E]**
 - ee. Failure to satisfy indebtedness to Racking Horse Breeders' Association of America or Racking Horse Breeders' Association of America affiliated/sanctioned events, or conducting any business or activities with the RHBA while indebtedness remains unsatisfied **[F]**

Section 18.2 VIOLATIONS BY JUDGES

The following violations apply to persons acting in the capacity of Judge. All of the following violations are considered Class E violations and are subject to the maximum penalty set forth in Section 18.4D herein.

- a. A Judge committing acts of fraud, deceit or misrepresentation in obtaining his or her license, or failing in bad faith to comply with the Bylaws and rules concerning licensing procedures **[E]**
- b. A Judge committing acts of gross negligence, incompetence or misconduct in carrying out his or her judicial duties or responsibilities **[E]**
- c. A Judge violating the Code of Professional Ethics for Judges

licensed by the Racking Horse Breeders' Association of America [E]

- d. A Judge making, authorizing or otherwise encouraging any public, oral or written statement of a derogatory nature concerning another licensed Judge or the Racking Horse Breeders' Association of America [E]
- e. A Judge exhibiting or acting as agent, representative in any capacity, or handler of a Racking Horse in any approved class at a show or contest at which he or she is officiating, or permitting an immediate family member to do the same; or judging any Racking Horse of which that Judge has been owner, trainer, agent in any capacity, or conditioner within the previous 30 days. If such a Racking Horse is entered in a show, its entry fee shall be refunded and it shall not be exhibited [E]
- f. Acting as a Judge at a Racking Horse Breeders' Association of America affiliated/sanctioned show in which a Racking Horse is shown whose owner or rider receives payments for training services from such Judge, within a 30-day period prior to show [E]
- g. A Judge, during the course of any approved show at which he/she is judging, being the houseguest of any person who is exhibiting in his Division at any show [E]
- h. A Judge failing to dismiss any horse whose actions threaten or endanger other exhibitors [E]
- i. A Judge advertising his or her services to the general public in official or unofficial publications representing the Racking Horse in general [E]
- j. A judge officiating at a show not affiliated/sanctioned by the RHBAA, without written permission from the RHBAA [E]
- k. A Judge failing to report to the Rules Enforcement Committee any communication, direct or indirect, from trainers, exhibitors or any other person having an interest in competition at a forthcoming show with regard to a tie or ties at such show [E]
- l. A Judge failing to excuse from the ring any horse suspected to be in violation of the Rules of the RHBAA [E]

PART B-PENALTIES

Section 18.3 PENALTIES CLASSIFICATION

- A. **CLASS A VIOLATIONS:** Persons who commit Class A violations are subject to a maximum of 30 days suspension from showing and 6 months probation and up to a \$100.00 fine.
- B. **CLASS B VIOLATIONS:** Persons who commit Class B violations are subject to a maximum of 30 days suspension from showing, one year probation and up to \$200.00 fine (or an amount as set from time to time by the Board of Directors of the RHBAA).
- C. **CLASS C VIOLATIONS:** Persons who commit Class C violations are subject to a maximum of 6 months suspension from showing, two years probation and up to a \$300.00 fine (or an amount as set from time to time by the Board of Directors of the RHBAA).
- D. **CLASS D VIOLATIONS:** Persons who commit Class D violations are subject to a maximum of one year suspension of all privileges of membership in the Racking Horse Breeders' Association of America, five years probation and up to \$500.00 fine (or an amount as set from time to time by the Board of Directors of the RHBAA).
- E. **CLASS E VIOLATIONS:** Persons who commit Class E violations are subject to a maximum of suspension of all privileges of membership in the Racking Horse Breeders' Association of America, expulsion from the Racking Horse Breeders' Association of America and up to \$1,000.00 fine (or an amount as set from time to time by the Board of Directors of the RHBAA).
- F. **CLASS F VIOLATIONS:** Persons who commit Class F violations are subject to being placed on the Racking Horse Breeders' Association of America Forfeit List and suspended from showing or having horse(s) shown or conducting **any** business or activities with the RHBAA until such indebtedness is paid.
- G. **PROBATION:** If any person on probation shall commit another offense of the same seriousness or greater during the probationary period, they shall be subject to a maximum

penalty twice as severe as that provided herein for the more recent offense, in the discretion of the Rules Enforcement Committee.

ARTICLE XIX

INDEMNIFICATION

Section 19.1 INDEMNIFICATION: The RHBAA shall indemnify and hold harmless, including paying attorneys fees and the cost of defense, any Director or officer, or former Director or officer of the RHBAA, from any and all claims or suits brought by a third person against such Director or officer on account of, or related to, his services as such Director or officer of the RHBAA, except that this indemnity obligation shall not apply to any intentional or criminal act of an officer or Director.

ARTICLE XX

AMENDMENTS OF BYLAWS

Section 20.1 BY MEMBERS: These bylaws may be amended, in accordance with article 7.2 of the Articles of Incorporation of the RHBAA: however in order for an amendment to be considered or made by the members of the RHBAA, at the annual or a special meeting, it must be submitted to the secretary of the RHBAA in writing at least 45 days prior to the membership meeting. The secretary shall mail a copy of such proposed amendment to each member, along with a notice of the meeting or if a notice of the meeting is published in a newspaper as provided for herein, then such proposed amendment may likewise be published. (This is the 15-day notice changed to 45-day notice) (2/19/05)

Section 20. 2 BY BOARD OF DIRECTORS: See Section 7.2 of the Articles of Incorporation which provides, in part, as follows: “Any of the Bylaws of this corporation may be amended by a majority vote of a quorum of the Directors present at a regular or special meeting.” Any amended Bylaw to be ratified by a majority vote of

a quorum of members entitled to vote before the bylaw is adopted. This amendment to be retroactive to the first day of January Year 2001 and by a majority vote of a quorum of the members present at the annual meeting or any special meeting. The exception is that the location of the principal office of the RHBAA, the Spring and Fall celebrations and annual meeting of members, and the requirement of blood typing as provided in the Articles of Incorporation.

ARTICLE XXI

MISCELLANEOUS

Section 21.1 CORPORATE SEAL: The Seal of the RHBAA shall be circular in form with the name of the RHBAA, the year of its organization and the words, "Corporate Seal - Alabama" inscribed thereon. The seal may be used by causing it to be affixed or impressed, or a facsimile thereof may be reproduced or otherwise used in such a manner as the Board of Directors may determine.

Section 21.2 FISCAL YEAR: The fiscal year of the RHBAA shall be from January 1 to December 31, inclusive, in each year, or such other twelve consecutive months as the Board of Directors may designate.

Section 21.3 NOTICE: WAIVER OF NOTICE: Whenever any notice is required to be given under any provision of law, the Articles of Incorporation, these Bylaws or the Rules of the RHBAA, such notice shall be deemed to have been given on the day upon which it was hand delivered to the recipient or, if mailed, on the day on which it was deposited in the United States mail. Whenever any notice is required to be given under any provision of law, the Articles of Incorporation, or these Bylaws, a written waiver thereof, signed by the person or persons entitled to such notice, whether before or after the time stated therein, shall be deemed equivalent to notice. Neither the business to be transacted at, nor the purpose of any regular or special meeting of the Members, Directors or members of a committee of Directors, need be specified in any written waiver of notice unless so required by the Articles of Incorporation. Attendance of a person at a meeting shall constitute a waiver of

notice of such meeting, except when the person attends a meeting for the express purpose of objecting, at the beginning of the meeting, to the transaction of any business because the meeting is not lawfully called or convened.

Section 21.4 EXECUTION OF INSTRUMENTS, CONTRACTS, ETC

(a) All checks shall be signed by the person expressly authorized and designated by name by the Board of Directors or Executive Board, provided that all checks must be signed by at least the Executive Director or an authorized officer of the RHBAA and countersigned by one other person designated by the Board of Directors.

(b) All promissory notes, contracts involving goods or services valued in excess of \$1500.00, deeds or mortgages, or contracts relating to land, and all other important documents must be signed by the President of the RHBAA, unless specific authorization has been given to another director by the Board of Directors or Executive Board.



**RACKING HORSE
BREEDERS' ASSOCIATION
OF AMERICA**

**67 Horse Center Road
Decatur, AL 35603
256/353-7225
FAX: 256/353-7266**